

TSURUMI AVANT

SERIES

MQ

SUBMERSIBLE
SEWAGE PUMPS

IE3
PREMIUM
EFFICIENCY
MOTOR



TSURUMI AVANT

“TSURUMI AVANT” is a new brand of submersible pumps and wastewater treatment equipment developed with an eye on the future by TSURUMI, a leading company in the field of submersible pumps for over 95 years. TSURUMI created it to deliver the maximum in customer satisfaction, by pooling years of know-how garnered with submersible pumps and wastewater treatment equipment into a series of premium grade products. This includes completely revamping everything from the materials used for components to the product lineup itself. The new brand is being released under the name of “TSURUMI AVANT.”

Tsurumi MQ-series pump design centres on **3 key concepts**, which guided the Tsurumi engineers in the creation of a genuinely hi-tech product.



Innovation

Innovating means improving, starting with yourself. We have responded with enthusiasm to a fast-changing market and worked passionately to deliver a high-quality product, the shining gem of today's Tsurumi range. **Tsurumi MQ-series** is innovative in performance and technology.



Reliability

A product's quality lies first and foremost in its **reliability**, meaning trouble-free operation with low maintenance. **Tsurumi MQ-series** is the outcome of painstaking design, machining on state-of-the-art machining centres, and meticulous assembly where the worker's experience plays a vital role.



Efficiency

Since operating costs usually account for a higher proportion of expenditure than other cost factors (purchase, installation and maintenance), design engineers aim to maximise efficiency to reduce running costs.

The **Tsurumi MQ-series** range is designed to be **modular**: the breadth of range allows an energy-saving **motor** in Premium IE3 class to be combined with high-efficiency **hydraulics** optimised for the duty point. The result? High total efficiency and sharply lower costs and environmental impact.

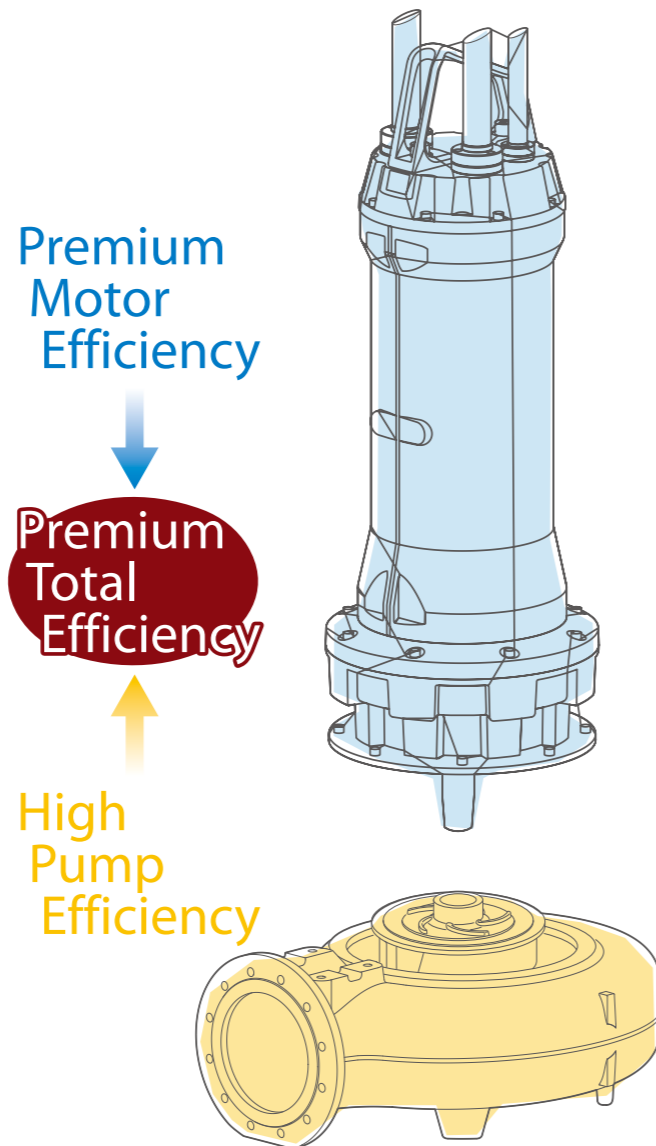

Tailor-made solutions

Tsurumi MQ-series is developed to give the best performance for the duty point, with energy saving assured by efficiency class IE3 motors and high-performance hydraulics.

Combining a multinational mentality with flexibility, Tsurumi guarantees effective solutions and products and systems that are genuinely "made to measure".

A modular range

The **Tsurumi MQ-series** is designed with **modularity** in mind. This approach gives the customer access to a large number of motor-hydraulics-material combinations, so every model is optimised for its intended use.

In practice, hydraulics of a given diameter and material can be fitted with motors with different powers and rpm for peak efficiency, and different types, dimensions and builds of impeller can be chosen depending on the specific criticalities of the application.

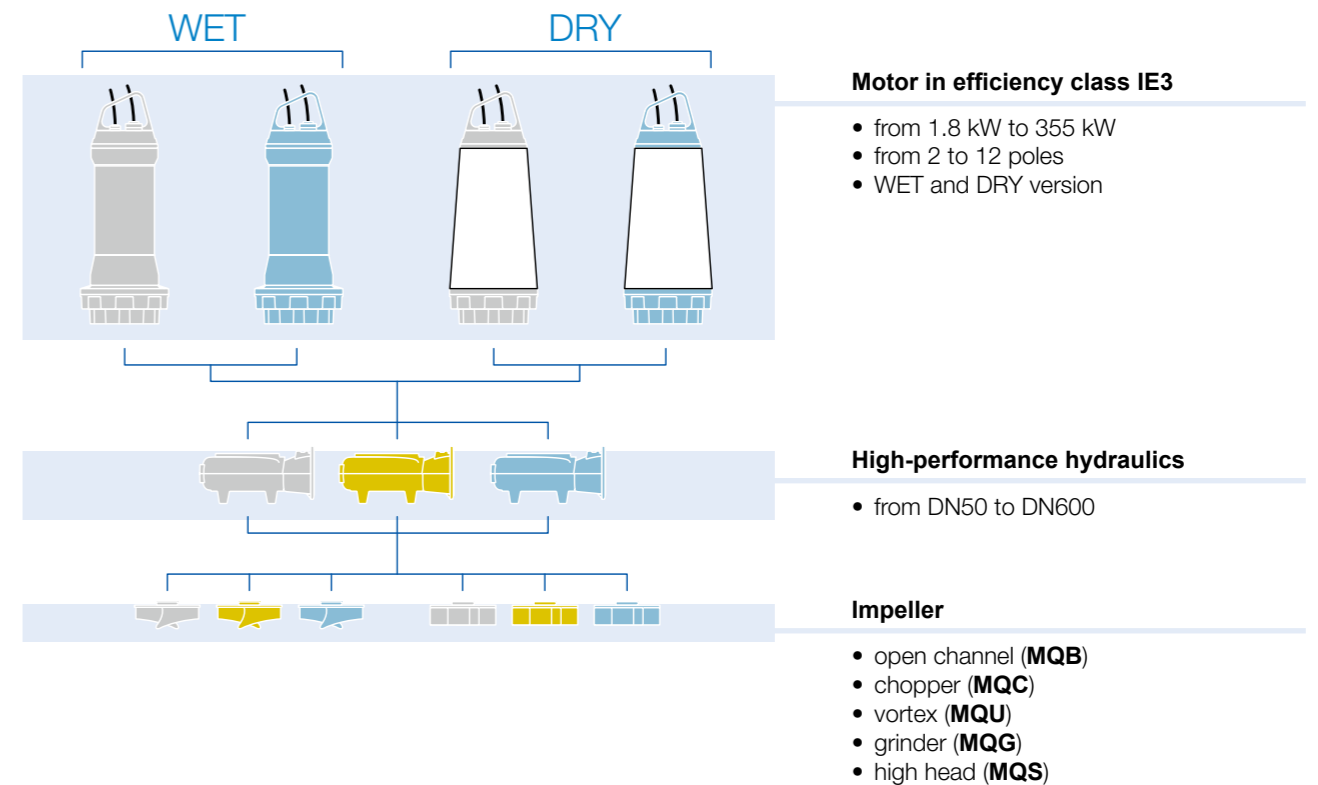

More materials, more reliability

To deal with special and specific applications, the standard iron hydraulics can be replaced with an alternative solution in bronze, stainless steel or *Molib-tech™*, an **innovative material** that guarantees constant performance even with very abrasive liquids, and significantly longer lifetime than conventional ceramic coating systems.

This means longer maintenance intervals, less inconvenience from system stoppages and lower incidence of running costs than with conventional pumping systems.

MQ-series

The MQ-series of the “TSURUMI AVANT” brand adds an IE3 premium efficiency motor to premium grade of submersible sewage pumps that Tsurumi makes. With this new series, overall efficiency and energy-savings have been taken to new heights by pursuing greater efficiency in both the pump and motor. Moreover, to ensure users get what they are looking for, the MQ-series offers 5 types of impellers (Open Channel, Chopper, Vortex, Grinder and High Head) and super wide ranges of specifications featuring 50 to 600 mm discharge bore diameters and 1.8 to 355 kW motor output specifications. Plus, pump installation can be chosen between a WET version that submerges the pump in water or a DRY version that installs the pump indoors or outside the tank using the original closed jacket cooling system with internal recirculation. Furthermore, MQ-series pumps accordance with IECEx explosion-proof specifications, and can be used in dry pits and other sites.

Characteristics

- Cast iron structure (stainless steel on request)
- Class H electric motor from 1.8 kW to 355 kW in efficiency class IE3
- 50 Hz and 60 Hz versions
- Thermal protection devices incorporated in stator
- Long life bearings (100,000 hours)
- AISI 431 drive shaft (AISI 329 on request)
- Leakage detection system in seal chamber (standard) and motor (on request)
- Two silicon carbide mechanical seals with Oil Lifter in large oil chamber
- Discharge from DN50 to DN600
- Large free passage declared for every model
- WET or DRY version available
- Original closed jacket cooling system with internal recirculation
- Operating temperature up to 60°C (up to 80° on request)
- Explosion-proof (Designed in accordance with IECEx)



Overview of operating ranges

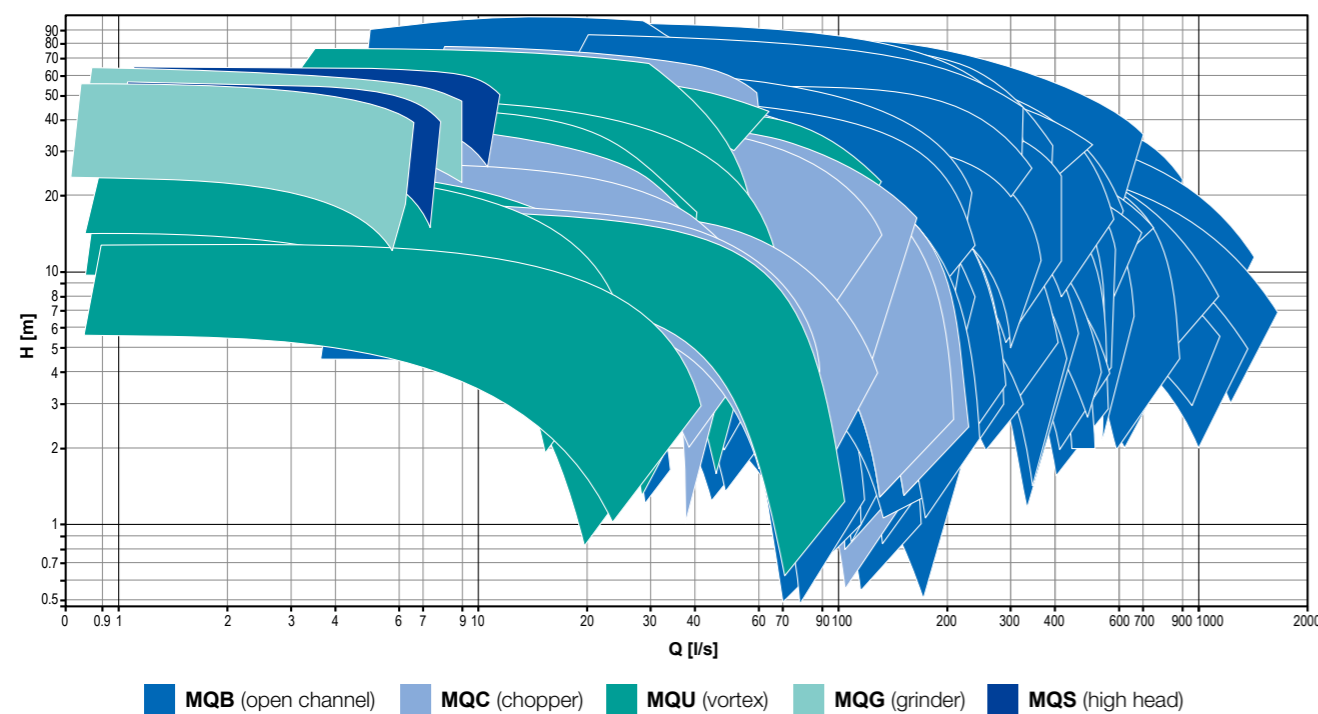

Construction materials

	Standard	Optional
Lifting handle	Stainless steel	-
Motor complex	EN-GJL-250	Stainless steel
Drive shaft	AISI 431	AISI 329
Cooling jacket	AISI 304	-
Gaskets	NBR	FPM (FKM)
Nuts and bolts	A2-70 Stainless Steel	A4-80
Hydraulics	EN-GJL-250	AISI 316 / AISI 329 Duplex / Molib-tech™
Impeller	EN-GJL-250	AISI 316 / AISI 329 Duplex / Br-Al / Molib-tech™

Standard equipment and options

	Standard	Optional	
Power voltage tolerance	max ± 10% (S3 duty)	-	
	max ± 5% (S1 duty)		
Efficiency class	IE3 - Premium Efficiency	IE2 - High Efficiency	
Motor insulation class	H	-	
Starting	Star-Delta	D.O.L, Soft Start	
Maximum ambient temperature	40 °C	60 °C or above	
Type of cable	S1RN8-F or equivalent	EMC (VFD)	
Cable length	10 m	20 - 30 - 40 - 50 m	
Painting	Bicomponent epoxy - 200 µm	Bicomponent epoxy - 400 µm	
Mechanical seals	2 SiC/SiC mechanical seals in oil chamber	-	
Thermal sensors	Bimetal thermal sensors (150 °C)	PTC/PT100 thermistors	
Type of installation	Submersible (WET version)	Dry (DRY version) DRY version available with 4 kW and above but, closed jacket cooling system is installed from 5.5 kW and above.	
Oil chamber/ motor	compartment water leakage sensor (single signal)	YES	-
	oil chamber	NO	YES
	motor compartment	NO	YES
	motor compartment cover	NO	YES
Sacrificial anodes	NO	YES	
Vibration sensors (bearings)	NO	YES	
Temperature sensors (bearings)	NO	PTC/PTC100	
Explosion-proof	NO	Designed in accordance with IECEx (II 2G Ex db k IIB T4 / II 2D Ex tb IIIC T135°C)	

The data provided are not binding. Tsurumi reserves the right to modify any product without notice.

Features

WET

Explosion-proof specification is available as an option. (Designed in accordance with IECEx)

CABLE GLAND

Cable gland system with cable holder. The universal thread ring-nut can be removed to fix a rigid or flexible duct to the cable gland to protect the cable from physical and mechanical stresses. On request a special resin seal is applied to prevent all possibility of water leaking into the motor even if the outer sheath is torn.

ELECTRICAL CONNECTIONS

The terminal board, which simplifies electrical wiring procedures, is in an airtight compartment which can be fitted with a leakage detection sensor.

THERMAL SENSORS

Detects excess heat, therefore, protecting the pump against overheating.

PAINTING

Bicomponent epoxy paint, standard thickness 200 µm. (max 400 µm on request)

IE3 PREMIUM EFFICIENCY MOTOR

BEARINGS

Ball bearings with lifetime lubrication designed to guarantee 100,000 working hours. Optional sensors can monitor temperature and vibration to guarantee optimal performance.

WATER SENSOR

Sensor fitted as standard to detect water or moisture in the mechanical seal oil chamber.

Also standard on explosion-proof models.

MECHANICAL SEALS (with OIL LIFTER)

Two silicon carbide mechanical seals in oil sump to ensure excellent reliability even in heavy-duty conditions.

Thanks to a special component (oil lifter) the upper mechanical seal remains lubricated at all times, with more effective protection against wear.

SUCTION and DISCHARGE

The suction and discharge flanges can be ordered with holes of any standard type (UNI, ANSI, BS, etc.) to ensure perfect compatibility with the system and the accessories installed.

IMPELLER

The most suitable impeller can be selected for each application.

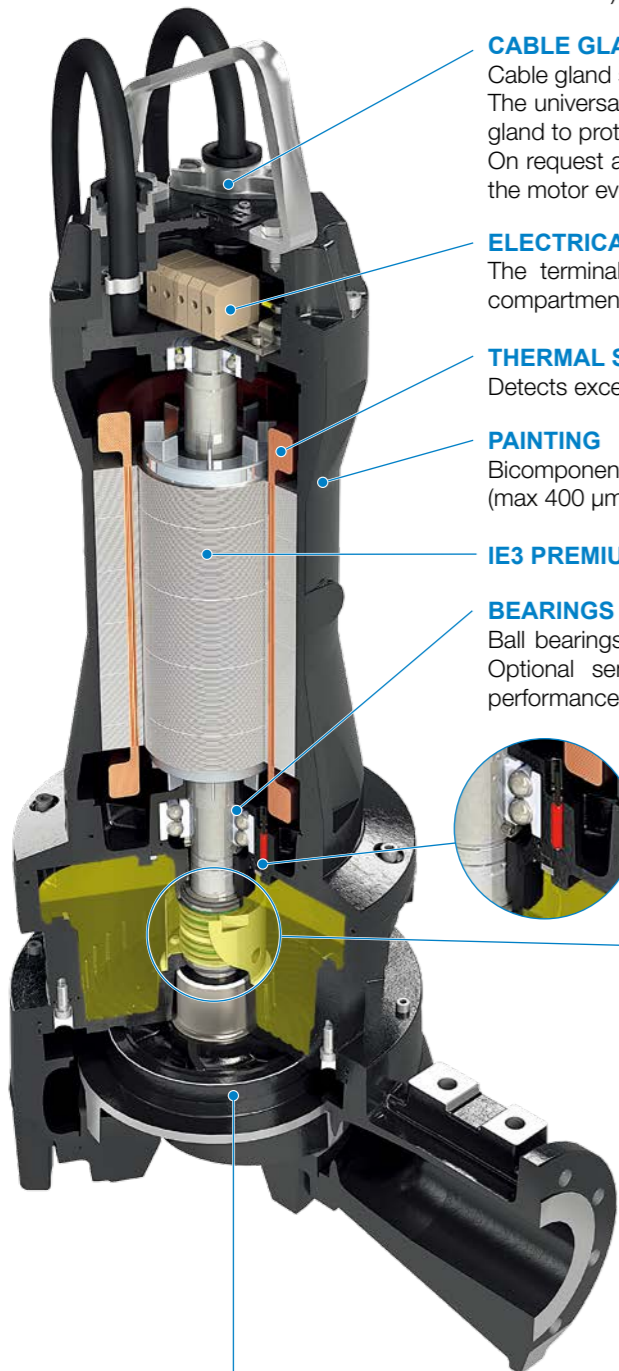

MQB
Open Channel
impeller



MQC
Chopper
impeller



MQU
Vortex
impeller



MQG
Grinder
impeller



MQS
High Head
impeller

Exclusive cooling system

DRY

DRY version available with 4 kW and above. In 5.5 kW and above of DRY version models, the motor is cooled by a water-glycol mix circulating in a special closed circuit.

The mix is recycled through the pump by an **axial impeller** rigidly mounted on the shaft and the specially designed steel **double jacket** which provides the necessary **heat exchange** between the motor and the external environment.

Thanks to this unique system:

- the cooling mix is **always separate from the wastewater** in which the pump is immersed and cannot be contaminated even if water leaks into the oil chamber due to wear of the first mechanical seal
- the mechanical seals are installed in an **oil chamber separated** from the cooling system and can be changed without draining the circuit

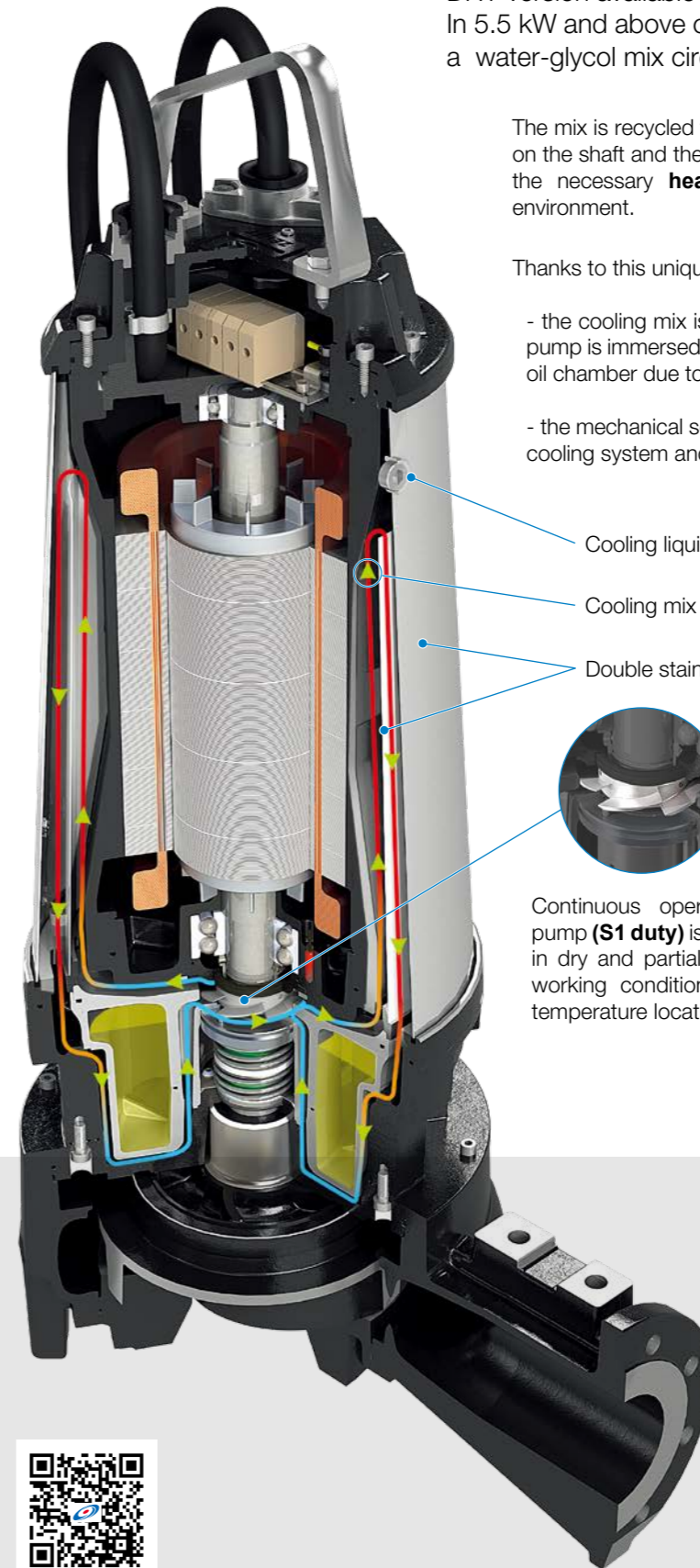

Cooling liquid inspection and filler cap

Cooling mix circulation path

Double stainless steel jacket

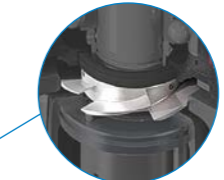

Axial recycling impeller

Continuous operation of the pump (**S1 duty**) is ensured even in dry and partially submerged working conditions or in high temperature locations.

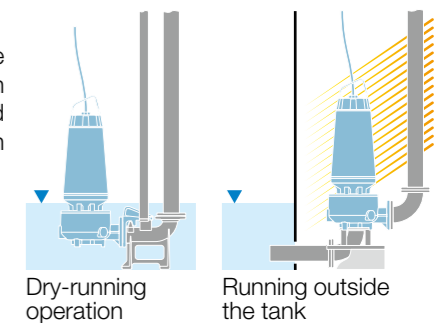

Dry-running operation

Running outside the tank

No unpleasant surprises

If the outer mechanical seal wears, the **sensor** warns that water is leaking into the oil chamber.

The second mechanical seal allows the pump to continue operating temporarily, allowing **scheduling of the maintenance job** with no need for unplanned system stoppages.



MQ-series
Features Movie

High efficiency motor

The heart of the **Tsurumi MQ-series** lies in its high-efficiency electric motors, designed to deliver high performances and withstand continuous duty cycles.

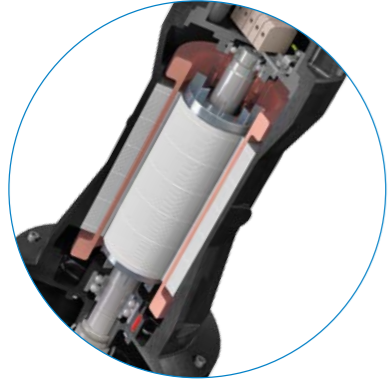

- **PREMIUM IE3** efficiency
- **NEMA Class A**
- **Class H** insulation for all models in the range.

S1 duty mode operation even in water at a temperature of 60°C or above.

Clogging-proof hydraulics

All hydraulic components are designed using latest-generation software for the highest efficiency and the **best performance** while still ensuring ample free passages.

All models with open channel impeller feature an **axial adjustment system** allowing the impeller clearance to be restored, to maintain performance even further to normal wear and tear.

One of the biggest problems in wastewater treatment application pumping industry is clogging of impeller due to fibrous and stringy materials. As a counter-measure to this clogging, TSURUMI AVANT's open channel impeller pumps have adopted new and innovative **Anti-Clogging System**. This **ACS** uses the centrifugal force of the impeller to pull out the stringy material via spiral groove of suitable depth cut into the diffuser plate. This effective measure eradicates the fibrous material clogging of the impeller.



More reliability with Molib-tech™

This **new material**, adopted by Tsurumi, is particularly suitable for preventing serious wear due to erosion or cavitation on pump impellers, suction flanges and bodies.



Through a complex research project, Tsurumi has developed a **new material** to:

- increase components' strength
- improve reliability
- keep performance constant over time even in extreme duty conditions.

This material, called *Molib-tech™*, is an alternative to the conventional ceramic coating process and **applies a layer of high-strength material to the iron**, to improve the product's **mechanical and performance characteristics**.

Unlike a conventional ceramic coating, the **uniform layer** of material does not cause any change in clearance or loss of performance.

Monitoring

Tsurumi MQ-series can be fitted with sensors for swift signalling of any anomaly, allowing quick action to protect the pump from potential damage.

The monitoring system also acquires data on the operation of the machines installed and helps in the targeted **planning of maintenance** to avoid sudden system shutdowns.

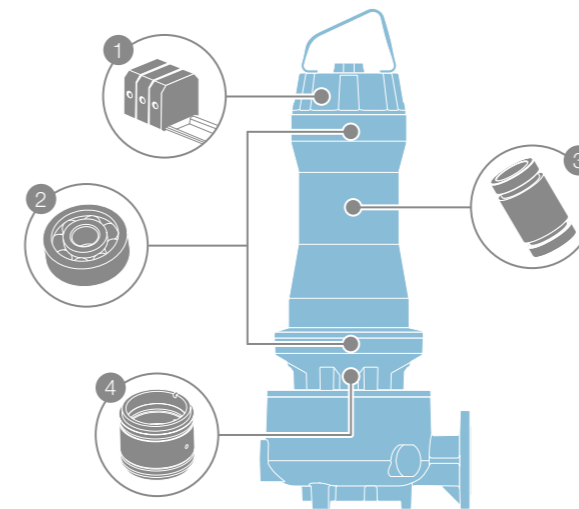

① **Terminal board:** water sensor that detects any leakage of water through the top cover to protect the motor (on request).

② **Bearings:** sensor (PT100) that signals overheating (on request) and vibration sensor warning of any impeller imbalance due to damage or cavitation (on request).

③ **Motor:** overheating bi-metal sensor (standard). PTC - PT100 on request. Independent sensors on each winding. Leakage detection sensor (on request).

④ **Oil chamber:** Water sensor (on request)

Maintenance

The **MQ-series** has been carefully, rationally designed to ensure **easy maintenance** and **quick replacement** of parts subject to wear and tear.

• CABLE

All electrical connections are easily acceptable inside the top cover. A terminal board simplifies disconnection of the cable in the event of replacement.

• MECHANICAL SEALS

Once the impeller has been removed, the oil chamber containing the mechanical seals is accessed by just removing the ring-nut that holds them in place.

• OIL

The oil in the mechanical seal chamber can easily be replaced thanks to caps accessible from the outside regardless of whether the pump is installed horizontal or vertical.

• BEARINGS

They have standard characteristics, for low-cost maintenance and trouble-free sourcing of replacement parts.

• COOLING LIQUID

The water-glycol mix that cools the motor is in a closed circuit and does not need changing even in case of prolonged use.



MQB (Open Channel)

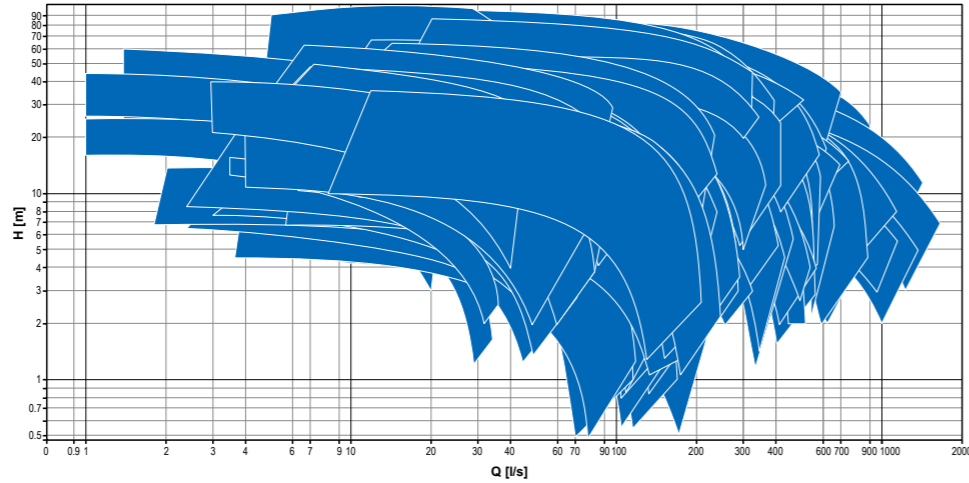

Range characteristics

Power	1.1 - 355 kW
Poles	2 / 4 / 6 / 8 / 10 / 12
Discharge	DN80 - 600
Free passage	max 220 x 110 mm
Max flow rate	1600 l/s
Max head	100 m

Hydraulics

- Open channel impeller
- High hydraulic performances

Suitable for

- Dense, heavily soiled wastewater
- Sewage treatment systems, civil and industrial lifting

MQC (Chopper)

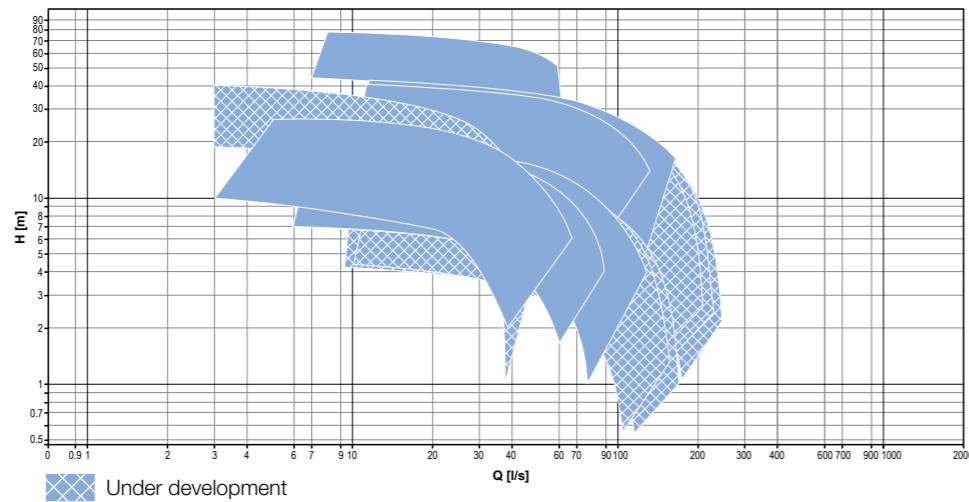

Range characteristics

Power	3 - 45 kW
Poles	2 / 4 / 6
Discharge	DN80 - 250
Free passage	-
Max flow rate	244 l/s
Max head	75 m

Hydraulics

- Chopper impeller in *hard cast iron* as standard
- Solids grinding system and anti-fouling hydraulics for virtually unlimited free passage

Efficiency of hydraulics only 3/5% less than that of a normal channel impeller

Suitable for

- Liquids containing large-sized solids which can be broken down
- Sewage systems

MQU (Vortex)

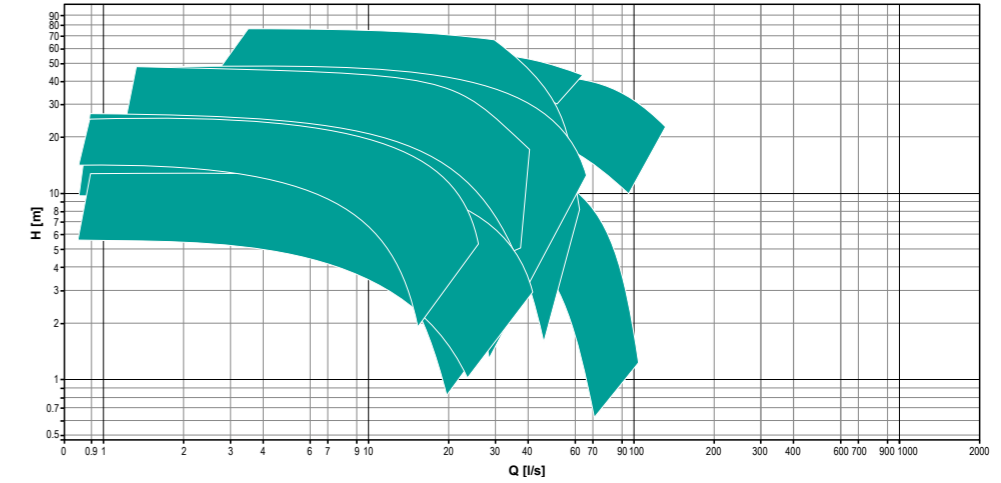

Range characteristics

Power	3 - 45 kW
Poles	2 / 4
Discharge	DN65 - 150
Free passage	max 125
Max flow rate	110 l/s
Max head	75 m

Hydraulics

- Vortex impeller
- Full free passage

Suitable for

- Liquids containing suspended solids
- Sewage and drainage systems and first rainfall tanks

MQG (Grinder)

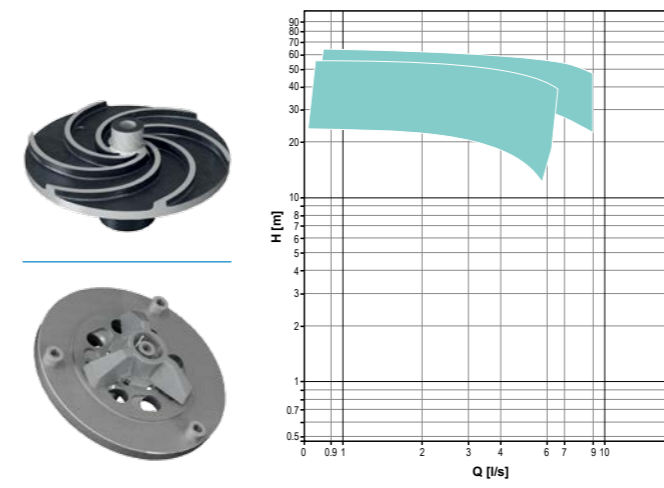

Range characteristics

Power	4 - 11 kW
Poles	2
Discharge	DN50-G2"
Free passage	-
Max flow rate	8.0 l/s
Max head	57 m

Hydraulics

- Grinding impeller
- Grinding system with three-blade rotary knife

Suitable for

- Wastewater containing solids which can be broken down and filaments
- Sewage treatment systems, civil lifting

MQS (High Head)

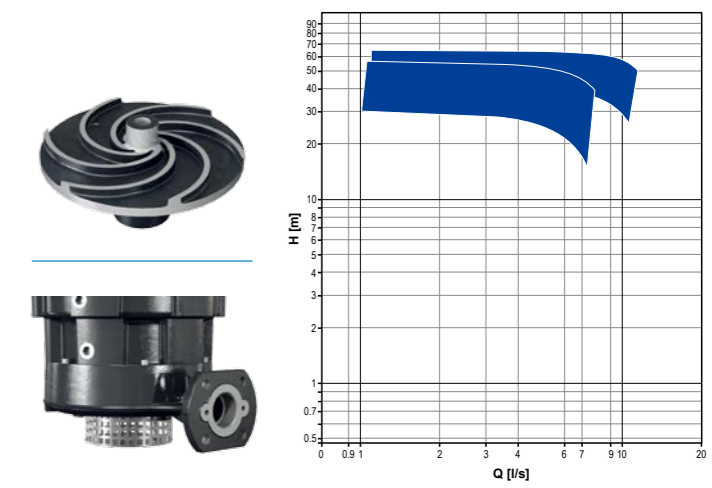

Range characteristics

Power	4 - 11 kW
Poles	2
Discharge	DN50-G2"
Free passage	max 10 mm
Max flow rate	11.0 l/s
Max head	61 m

Hydraulics

- Cast iron multi-channel open impeller
- High manometric head

Suitable for

- Clean, rain and seepage water
- Suitable for applications in agriculture, irrigation and fish farming



Quick and Easy Pump Selector!
Web: <https://tass.tsurumiavant.com>



Cod. 29040060900400000
Rev. 12 - 01/05/2019

We reserve the right to change the specifications and designs without prior notice. The OO series and model OO are indicated with our series/model codes in this catalog.

**TSURUMI
MANUFACTURING CO., LTD.**

Your Dealer