

CDSW

Vertically Staged

# Self Priming Centrifugal Pumps

Ultra V Basic Pump <sup>w/</sup> UltraMate Second Stage

Model VS6A60-B

Size 8" x 6"



**PUMP SPECIFICATIONS**

- Size:** 8" x 6" (203 mm x 154 mm).\*
- Pump Casings:** Gray Iron No. 30.†
- Maximum Operating Pressure 257 psi (1772 kPa).\*\*
- Semi-Open Type, Two Vane Impellers:** Ductile Iron No. 65-45-12.  
Handles 3" (76,2 mm) Diameter Spherical Solids.
- Impeller Shafts:** Alloy Steel No. 4140.
- Self-Cleaning Replaceable Wear Plates:** Carbon Steel No. 1015.†
- Shimless Adjustable Cover Plates:** Gray Iron No. 30.†
- Suction Flange:** Gray Iron No. 30.
- Bearing Housings:** Gray Iron No. 30.
- Seal Plates:** Gray Iron No. 30.
- Shaft Sleeves:** Alloy Steel No. 4130.
- Radial and Thrust Bearings:** Open Double Ball.
- Bearing and Seal Cavity Lubrication:** SAE No. 30 Non-Detergent Oil.
- Gaskets:** Buna-N, Compressed Synthetic Fibers, Vegetable Fiber, PTFE, Cork, and Rubber.
- O-Rings:** Buna-N.
- Transition Chamber:** Ductile Iron No. 65-45-12.†
- Hardware:** Standard Plated Steel.
- Brass Pressure Relief Valves.**
- Bearing and Seal Cavity Oil Level Sight Gauges.**
- Optional Equipment:** Automatic Air Release Valve. High Pump Temperature Shutdown Kit. Stainless Steel/G-R Hard Iron Impellers and Wear Plates. 120/240 Volt Casing Heater.
- \*Optional Gray Iron No. 30 Flange Kits Available as Follows  
(See Price Sheets):  
8" and 6" 125# Female NPT Suction/Discharge Flange Kits.  
8" and 6" ASA Suction/Discharge Spool Flange Kits.  
200 mm and 150 mm DIN 2527 (PN 16) Suction/Discharge Spool Flange Kits.

UltraMate  
Second  
Stage

Ultra V  
Basic  
Pump

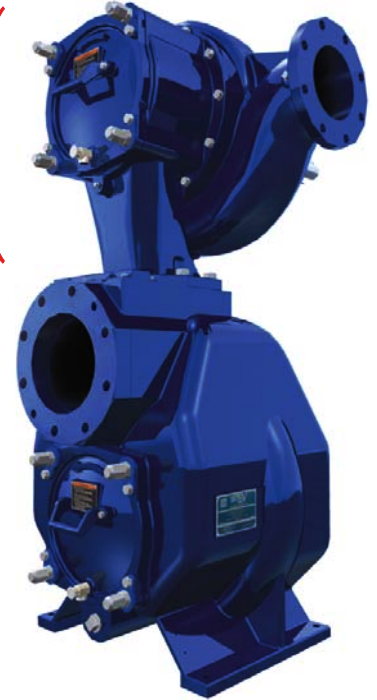

† Gorman-Rupp Patented/Patent Pending Feature.

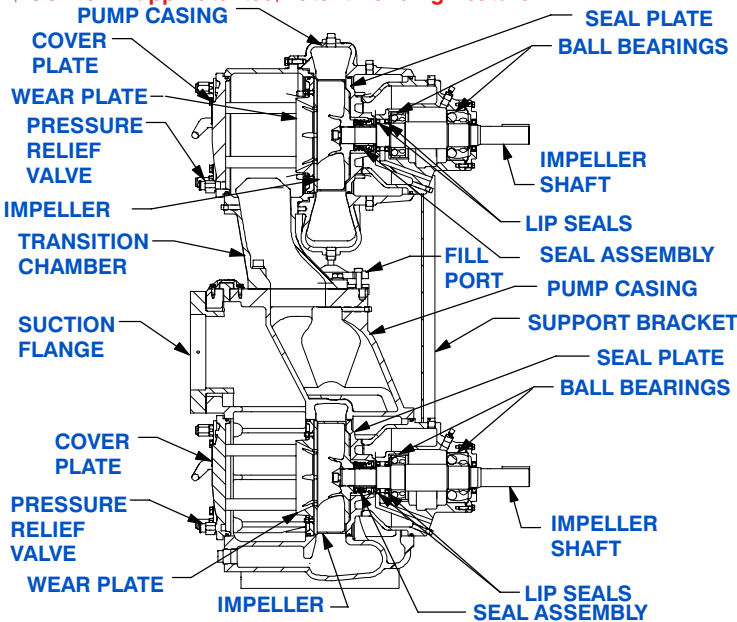

**SEAL SPECIFICATIONS**

Cartridge Type, Mechanical, Oil-Lubricated, Double Floating, Self-Aligning. Silicon Carbide Rotating and Stationary Faces. Stainless Steel No. 316 Stationary Seat. Fluorocarbon Elastomers (DuPont Viton<sup>®</sup> or Equivalent). Stainless Steel No. 18-8 Cage and Spring. Maximum Temperature of Liquid Pumped, 160°F (71°C).†\*\*

**\*\*Consult Factory for Applications Exceeding Maximum Pressure and/or Temperature Indicated.**

**SEAL DETAIL**

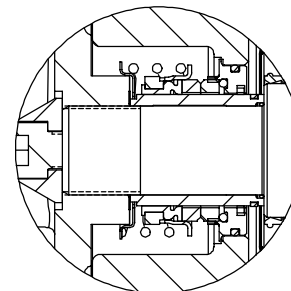

THE GORMAN-RUPP COMPANY • MANSFIELD, OHIO

GORMAN-RUPP OF CANADA LIMITED • ST. THOMAS, ONTARIO, CANADA

www.grpumps.com

Specifications Subject to Change Without Notice

Printed in U.S.A.

**Specification Data**

SECTION 55, PAGE 3200

**APPROXIMATE DIMENSIONS and WEIGHTS**

**NET WEIGHT:** 1900 LBS. (862 KG.)\*  
**SHIPPING WEIGHT:** 1975 LBS. (896 KG.)\*  
**EXPORT CRATE:** 74 CU. FT. (2,1 CU. M.)  
 \*WEIGHTS DO NOT INCLUDE OPTIONAL FLANGE KITS

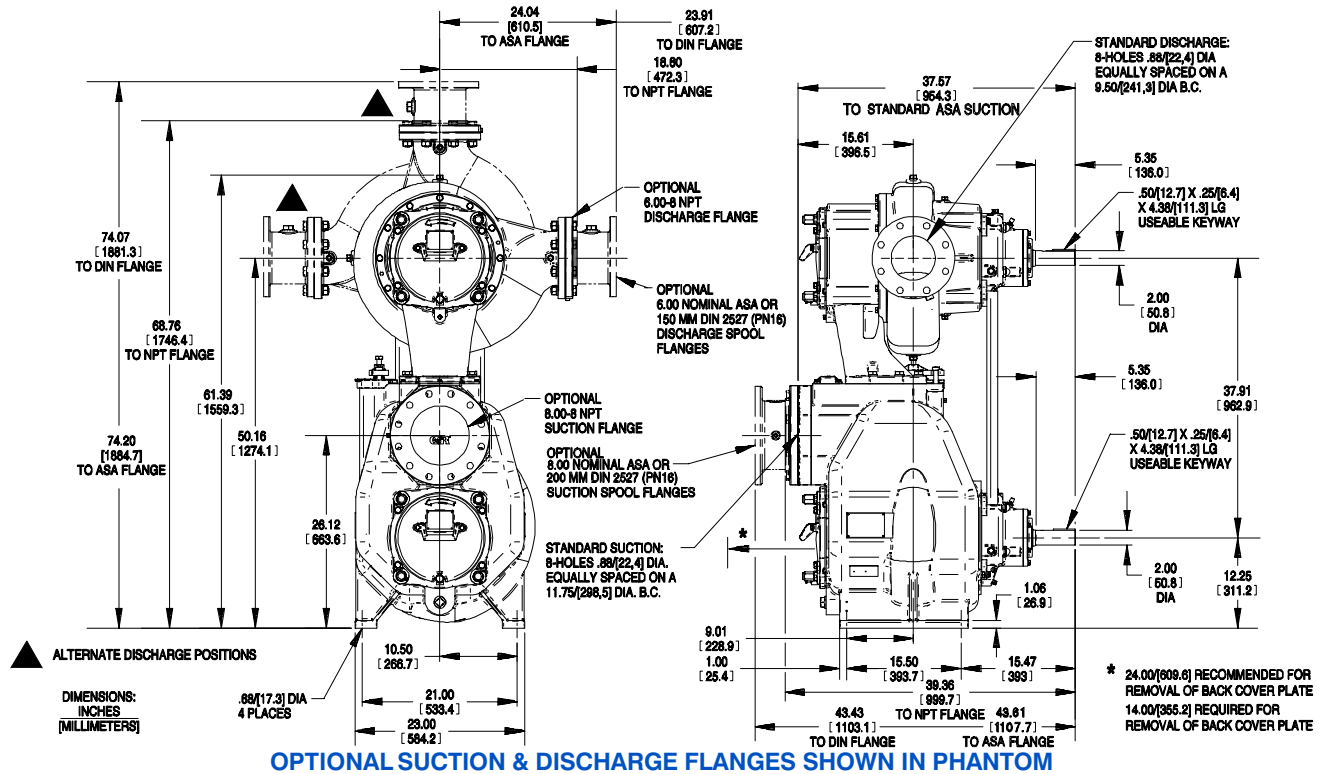

**OPTIONAL SUCTION & DISCHARGE FLANGES SHOWN IN PHANTOM**

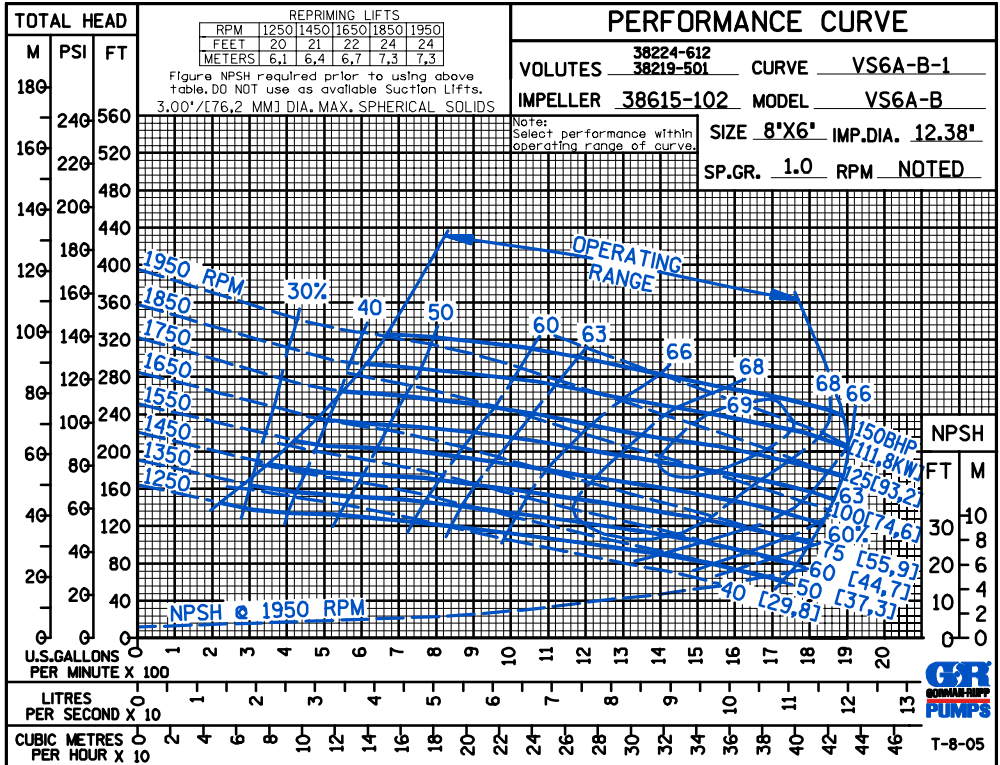

Total Combined H.P. Shown



**THE GORMAN-RUPP COMPANY • MANSFIELD, OHIO**

GORMAN-RUPP OF CANADA LIMITED • ST. THOMAS, ONTARIO, CANADA

Specifications Subject to Change Without Notice

Printed in U.S.A.