

DS

Self Priming Centrifugal Pump

Basic Pump

Model T8A3S-B

Size 8" x 8"

Super
T SERIES



PUMP SPECIFICATIONS

Size: 8" (203 mm) ASA Flanged Suction x 8" (203 mm) NPT Female Discharge.

Pump Casing: Gray Iron No. 30. Maximum Operating Pressure 83 psi (572 kPa).*

Open Type, Two Vane Impeller: Ductile Iron No. 65-45-12. Handles 3" (76,2 mm) Diameter Spherical Solids.

Impeller Shaft: Alloy Steel No. 4140.

Replaceable Wear Plate: Gray Iron No. 30.

Removable Adjustable Cover Plate: Gray Iron No. 30; 66 lbs. (30 kg).

Flap Valve: Neoprene w/Steel Reinforcing.

Bearing Housing: Gray Iron No. 30.

Seal Plate: Gray Iron No. 30.

Shaft Sleeve: Alloy Steel No. 4130.

Radial/Thrust Bearings: Open Double Ball.

Bearing and Seal Cavity Lubrication: SAE No. 30 Non-Detergent Oil.

Flanges: 125# Gray Iron No. 30.

Gaskets: Buna-N, Compressed Synthetic Fibers, PTFE, Cork, and Rubber.

O-Rings: Buna-N.

Hardware: Standard Plated Steel.

Brass Pressure Relief Valve.

Bearing and Seal Cavity Oil Level Sight Gauge.

Optional Equipment: Metal Bellows Seal. Automatic Air Release Valve. 120V/240V Casing Heater. High Pump Temperature Shutdown Kit. Gray Iron No. 30 Spool Flanges; 8" ASA Discharge (**Specify Model T8A3S-B /F**). 200 mm DIN 2527 Suction and Discharge (**Specify Model T8A3S-B /FM**).



Shown with Optional Discharge Spool Flange (Available in ASA or DIN Standard Sizes).

SEAL SPECIFICATIONS

Cartridge Type, Mechanical, Oil-Lubricated, Double Floating, Self-Aligning. Tungsten Titanium Carbide Rotating and Stationary Faces. Stainless Steel No. 316 Stationary Seat. Fluorocarbon Elastomers (DuPont Viton® or Equivalent). Stainless Steel No. 18-8 Cage and Spring. Maximum Temperature of Liquid Pumped, 160°F (71°C).*

*Consult Factory for Applications Exceeding Maximum Pressure and/or Temperature Indicated.

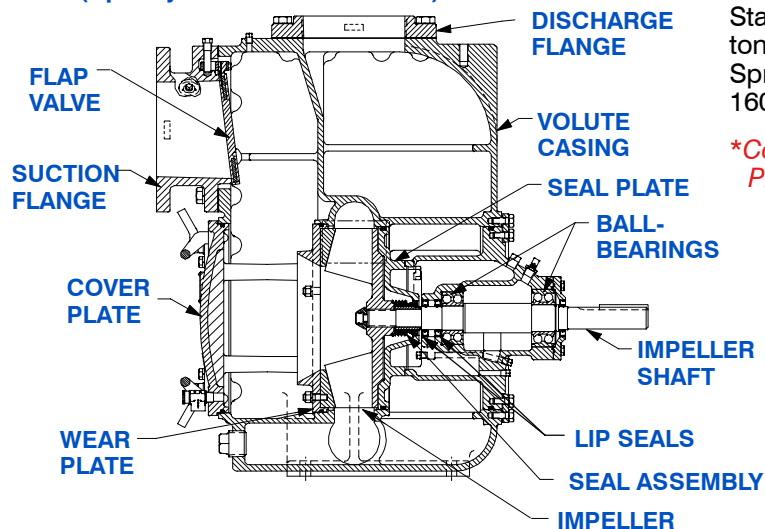

SEAL DETAIL

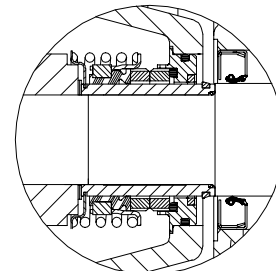

THE GORMAN-RUPP COMPANY • MANSFIELD, OHIO

GORMAN-RUPP OF CANADA LIMITED • ST. THOMAS, ONTARIO, CANADA

www.gormanrupp.com

Specifications Subject to Change Without Notice

Printed in U.S.A.

Specification Data

SECTION 55, PAGE 2300

APPROXIMATE DIMENSIONS and WEIGHTS

NET WEIGHT: 1295 LBS. (587 KG.)*
SHIPPING WEIGHT: 1399 LBS. (634 KG.)*
EXPORT CRATE: 47.9 CU. FT. (1,36 CU. M.)
***ADD 48 LBS. (21,8 KG.) W/ DISCH SPOOL FLANGE**

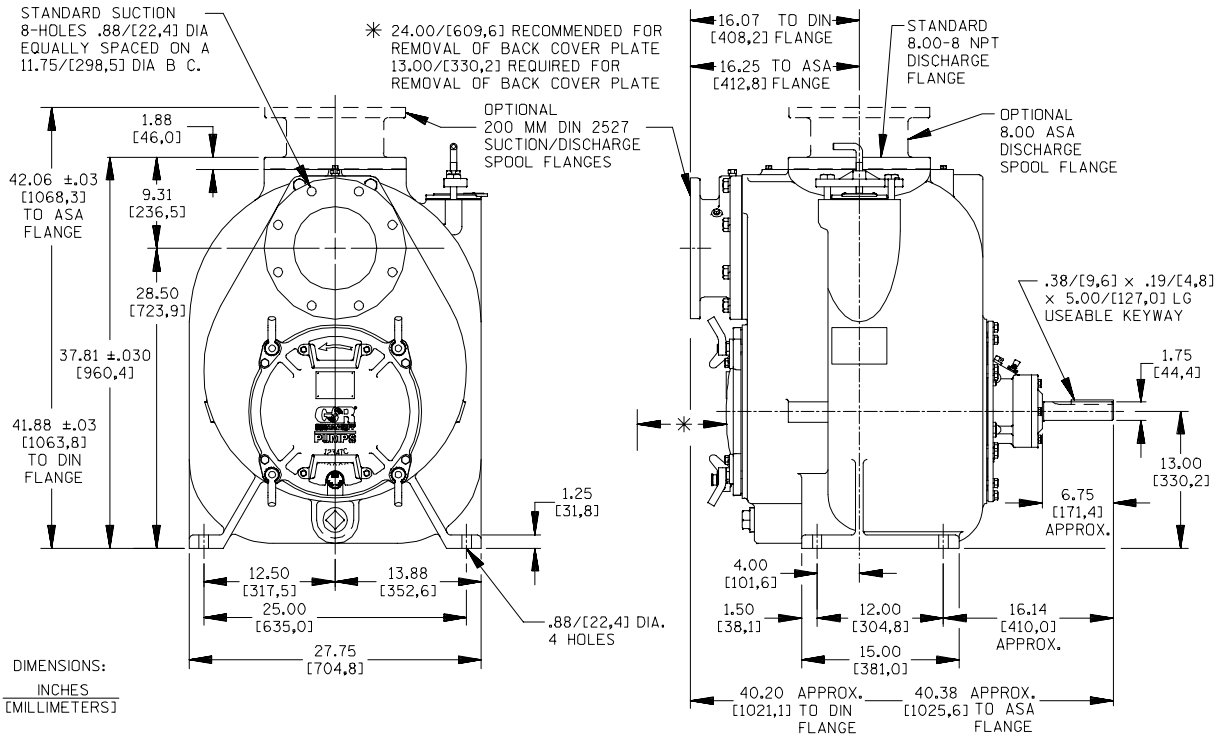

OPTIONAL ASA OR DIN STANDARD SPOOL FLANGES AVAILABLE

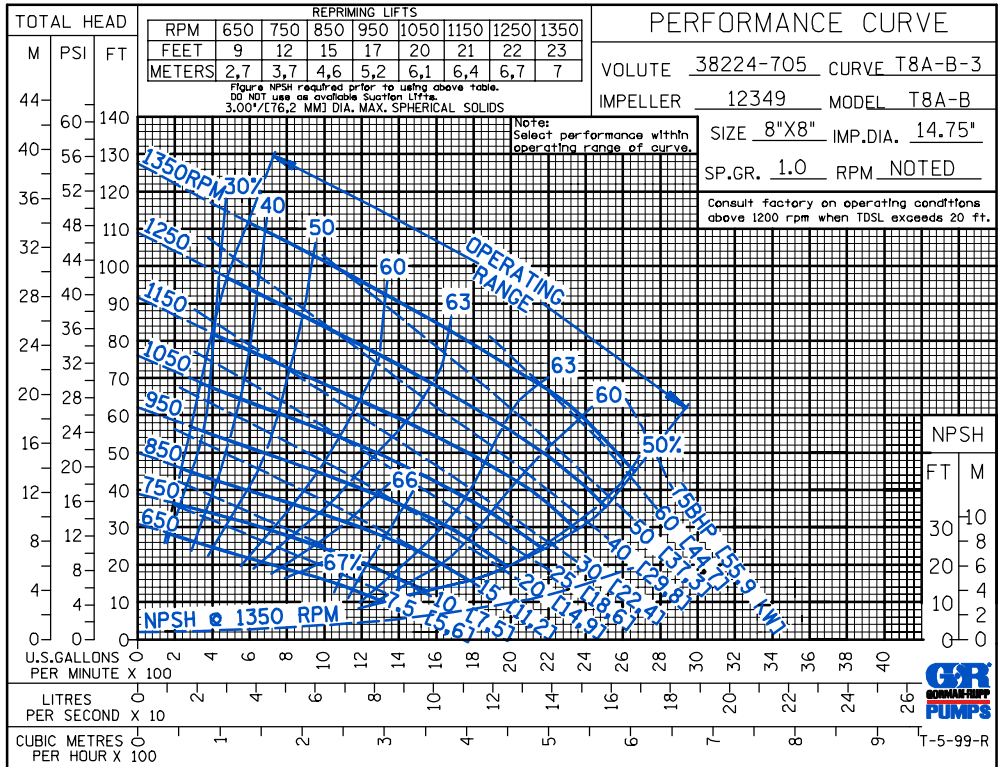

THE GORMAN-RUPP COMPANY • MANSFIELD, OHIO

GORMAN-RUPP OF CANADA LIMITED • ST. THOMAS, ONTARIO, CANADA

Specifications Subject to Change Without Notice

Printed in U.S.A.