

DS

Self Priming Centrifugal Pump

Basic Pump

Model T6A3S-B

Size 6" x 6"



PUMP SPECIFICATIONS

- Size:** 6" x 6" (152 mm x 152 mm) NPT - Female.
- Pump Casing:** Gray Iron No. 30. Maximum Operating Pressure 79 psi (545 kPa).*
- Open Type, Two Vane Impeller:** Ductile Iron No. 65-45-12. Handles 3" (76,2 mm) Diameter Spherical Solids.
- Impeller Shaft:** Alloy Steel No. 4140.
- Replaceable Wear Plate:** Carbon Steel No. 1015.
- Removable Adjustable Cover Plate:** Gray Iron No. 30; 50 lbs. (23 kg).
- Flap Valve:** Neoprene w/Steel Reinforcing.
- Bearing Housing:** Gray Iron No. 30.
- Seal Plate:** Gray Iron No. 30.
- Shaft Sleeve:** Alloy Steel No. 4130.
- Radial Bearing:** Open Single Ball.
- Thrust Bearing:** Open Double Ball.
- Bearing and Seal Cavity Lubrication:** SAE No. 30 Non-Detergent Oil.
- Flanges:** 125# Gray Iron No. 30.
- Gaskets:** Buna-N, Compressed Synthetic Fibers, PTFE, Vegetable Fiber, Cork, and Rubber.
- O-Rings:** Buna-N.
- Hardware:** Standard Plated Steel.
- Brass Pressure Relief Valve.**
- Bearing and Seal Cavity Oil Level Sight Gauges.**
- Optional Equipment:** Metal Bellows Seal. Automatic Air Release Valve. 120V/240V Casing Heater. High Pump Temperature Shutdown Kit.
- Gray Iron No. 30 Suction and Discharge Spool Flanges; 6" ASA (**Specify Model T6A3S-B /F**). 150 mm DIN 2527 (**Specify Model T6A3S-B /FM**).



Shown with Optional Suction & Discharge Spool Flanges (Available in ASA or DIN Standard Sizes).

SEAL SPECIFICATIONS

Cartridge Type, Mechanical, Oil-Lubricated, Double Floating, Self-Aligning. Tungsten Titanium Carbide Rotating and Stationary Faces. Stainless Steel No. 316 Stationary Seat. Fluorocarbon Elastomers (DuPont Viton® or Equivalent). Stainless Steel No. 18-8 Cage and Spring. Maximum Temperature of Liquid Pumped, 160°F (71°C).*

**Consult Factory for Applications Exceeding Maximum Pressure and/or Temperature Indicated.*

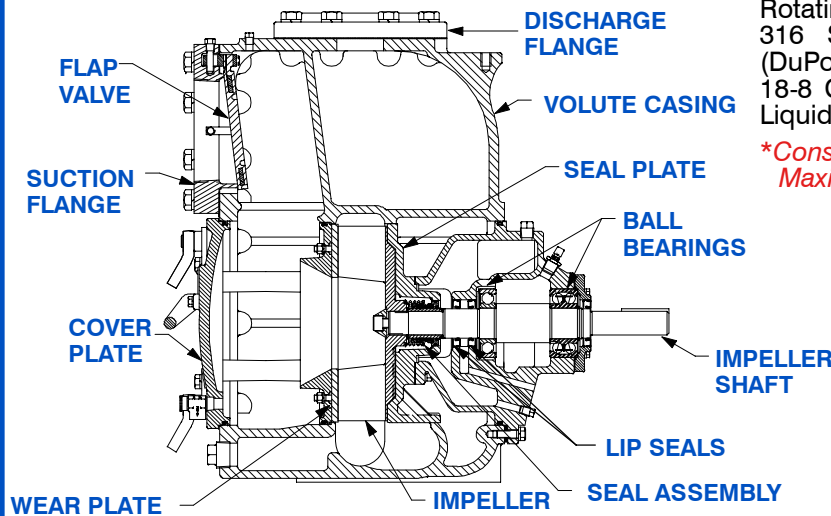

SEAL DETAIL

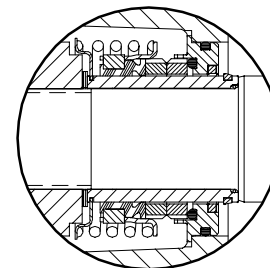

THE GORMAN-RUPP COMPANY • MANSFIELD, OHIO

GORMAN-RUPP OF CANADA LIMITED • ST. THOMAS, ONTARIO, CANADA

www.gormanrupp.com

Specifications Subject to Change Without Notice

Printed in U.S.A.

Specification Data

SECTION 55, PAGE 2200

APPROXIMATE DIMENSIONS and WEIGHTS

NET WEIGHT: 802 LBS. (364 KG.)*
SHIPPING WEIGHT: 862 LBS. (391 KG.)*
EXPORT CRATE: 32.5 CU. FT. (0,9 CU. M.)
***ADD 33 LBS. (15 KG.) W/EACH SPOOL FLANGE**

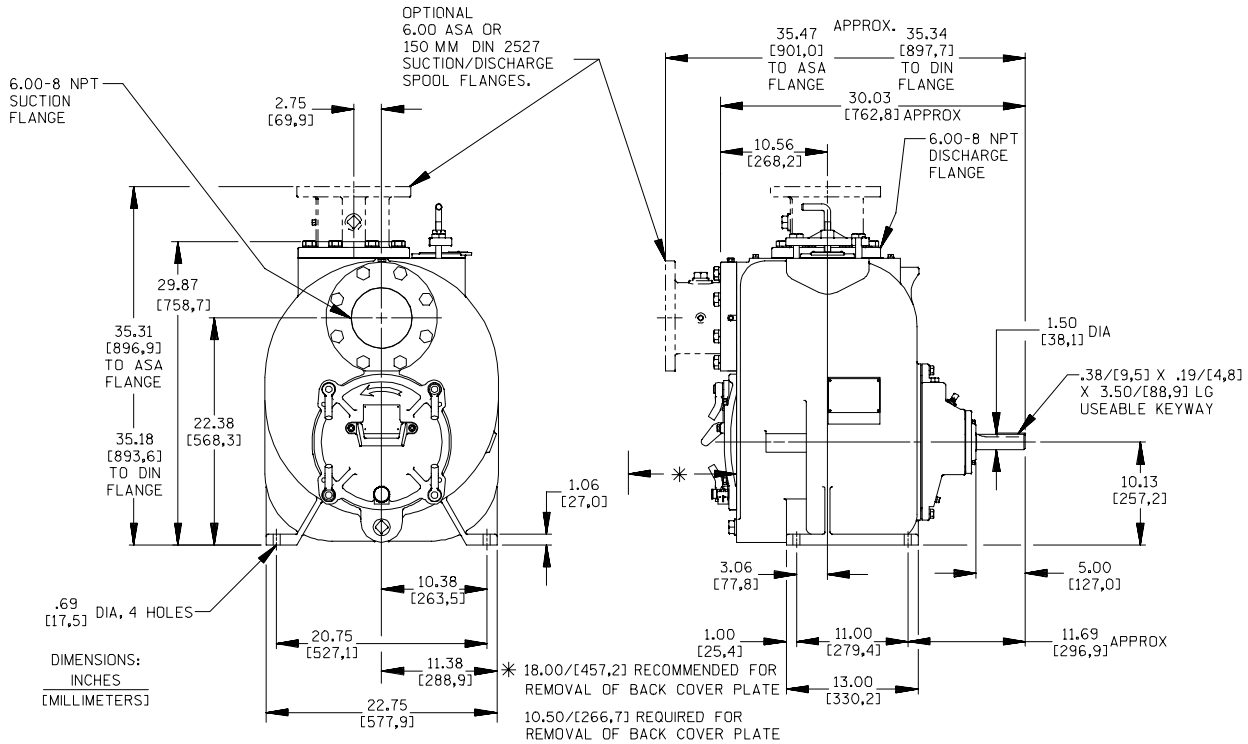

OPTIONAL ASA OR DIN STANDARD SUCTION & DISCHARGE SPOOL FLANGES AVAILABLE

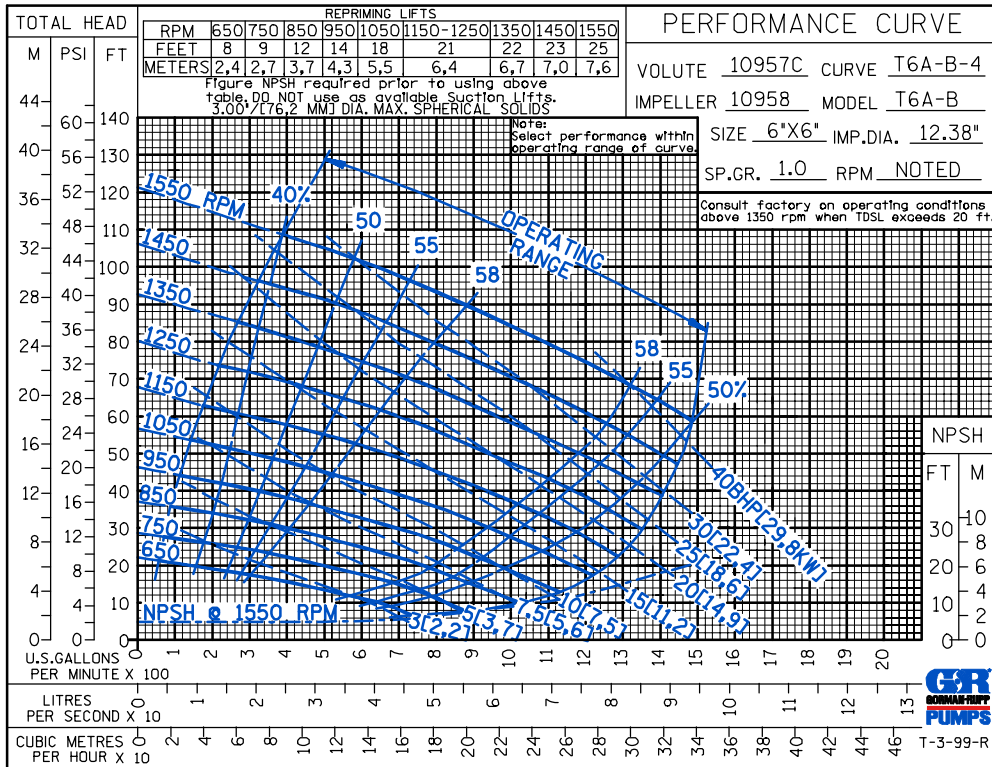

THE GORMAN-RUPP COMPANY • MANSFIELD, OHIO

GORMAN-RUPP OF CANADA LIMITED • ST. THOMAS, ONTARIO, CANADA

Specifications Subject to Change Without Notice

Printed in U.S.A.