

DS

Self Priming Centrifugal Pump

**Basic Pump****Model T2A3-B****Size 2" x 2"****PUMP SPECIFICATIONS****Size:** 2" x 2" (51 mm x 51 mm) NPT - Female.**Pump Casing:** Gray Iron No. 30. Maximum Operating Pressure 79 psi (545 kPa).***Open Type, Two Vane Impeller:** Ductile Iron No. 65-45-12. Handles 1 1/2" (38 mm) Diameter Spherical Solids.**Impeller Shaft:** Alloy Steel No. 4140.**Replaceable Wear Plate:** Carbon Steel No. 1015.**Removable Cover Plate:** Gray Iron No. 30; 20 lbs. (9 kg).**Bearing Housing:** Gray Iron No. 30.**Seal Plate:** Gray Iron No. 30.**Externally Replaceable Flap Valve:** Neoprene w/Steel Reinforcing.**Shaft Sleeve:** Alloy Steel No. 4130.**Radial Bearing:** Open Single Ball.**Thrust Bearing:** Open Double Ball.**Bearing and Seal Cavity Lubrication:** SAE No. 30 Non-Detergent Oil.**Suction Flange:** 125# Gray Iron No. 30.**Discharge Flange:** 125# Gray Iron No. 30.**Gaskets:** Buna-N, Vegetable Fiber, Cork and Rubber.**O-Rings:** Buna-N.**Internal Wetted Hardware:** Standard Plated Steel.**External Hardware:** Standard Plated Steel.**Brass Pressure Relief Valve.****Bearing and Seal Cavity Oil Level Sight Gauges.****Optional Equipment:** Automatic Air Release Valve.

120V/240V Casing Heater. High Pump Temperature Shut-down Kit. Gray Iron No. 30 Suction and Discharge Spool Flanges;

2" ASA (**Specify Model T2A3-B /F**).50 mm DIN 2527 (**Specify Model T2A3-B /FM**).**Shown with Optional Suction & Discharge Spool Flanges (Available in ASA or DIN Standard Sizes).****SEAL SPECIFICATIONS**

Mechanical, Oil-Lubricated, Double Floating, Self-Aligning. Tungsten Titanium Carbide Rotating and Stationary Faces. Stainless Steel No. 316 Stationary Seat. Fluorocarbon Elastomers (DuPont Viton® or Equivalent). Stainless Steel No.18-8 Cage and Spring. Maximum Temperature of Liquid Pumped, 160°F (71°C).*

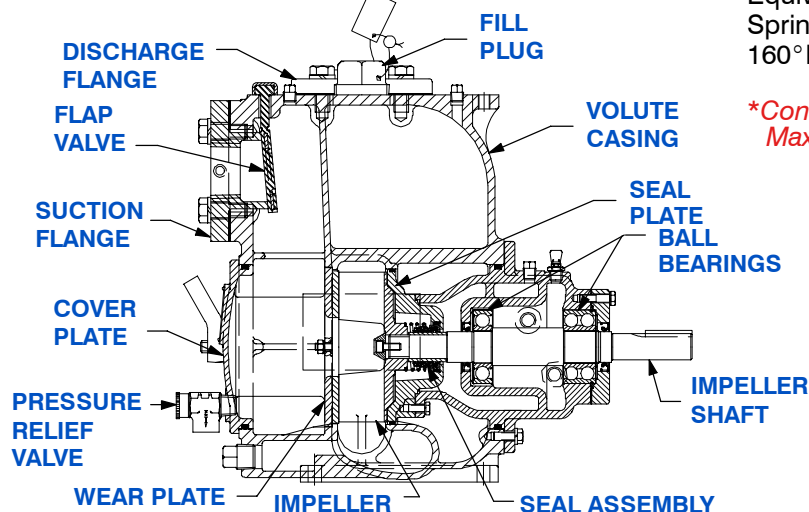
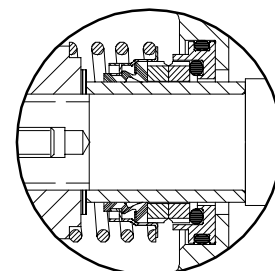
Consult Factory for Applications Exceeding Maximum Pressure and/or Temperature Indicated.*SEAL DETAIL****THE GORMAN-RUPP COMPANY • MANSFIELD, OHIO**

GORMAN-RUPP OF CANADA LIMITED • ST. THOMAS, ONTARIO, CANADA

www.gormanrupp.com

Specifications Subject to Change Without Notice

Printed in U.S.A.

Specification Data

SECTION 55, PAGE 980

APPROXIMATE DIMENSIONS and WEIGHTS

NET WEIGHT: 210 LBS. (95 KG.)*
SHIPPING WEIGHT: 250 LBS. (113 KG.)*
EXPORT CRATE: 5 CU. FT. (0,14 CU. M.)
***ADD 12 LBS. (5,4 KG.) W/EACH SPOOL FLANGE**

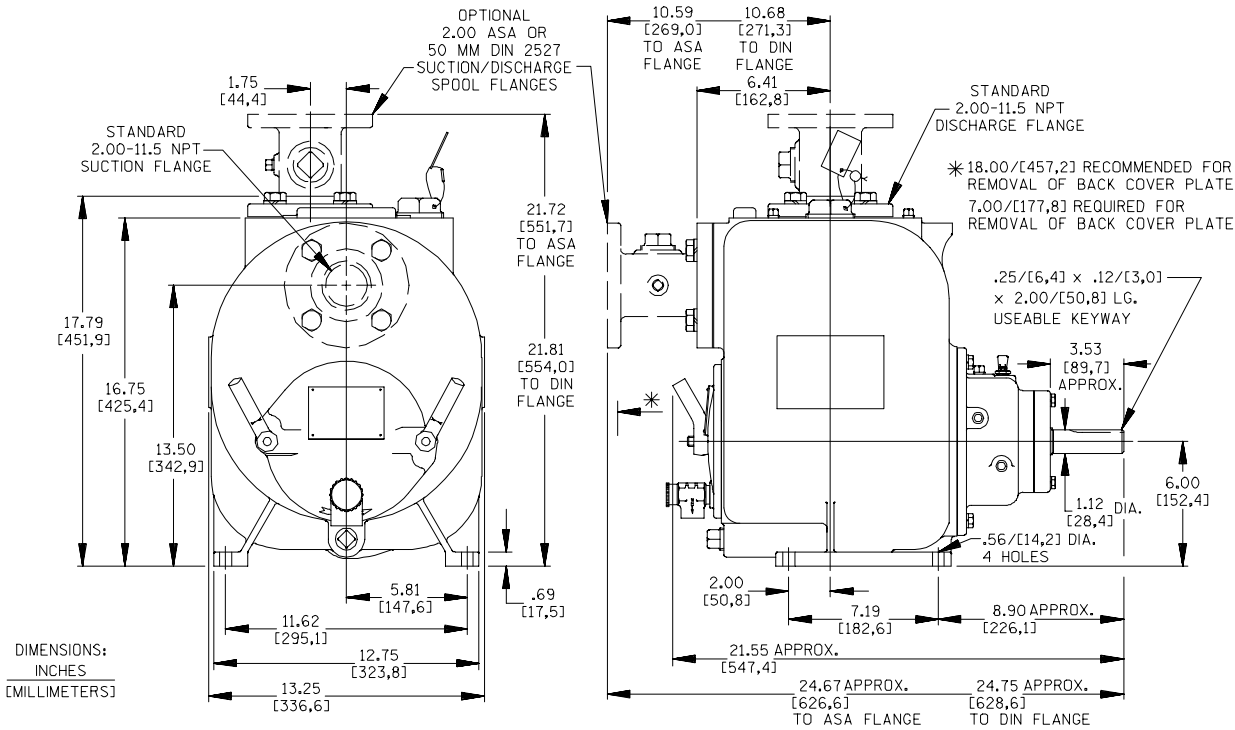

OPTIONAL ASA OR DIN STANDARD SUCTION & DISCHARGE SPOOL FLANGES AVAILABLE

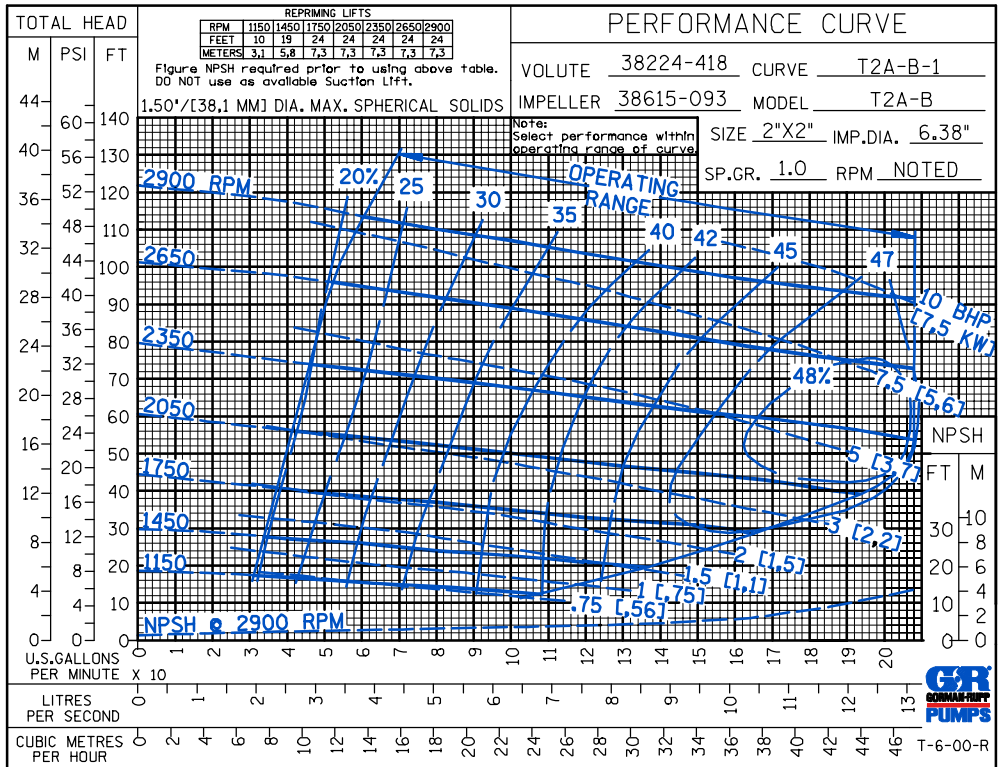

THE GORMAN-RUPP COMPANY • MANSFIELD, OHIO

GORMAN-RUPP OF CANADA LIMITED • ST. THOMAS, ONTARIO, CANADA

Specifications Subject to Change Without Notice

Printed in U.S.A.