

DS

Self Priming Centrifugal Pump

**Super
T SERIES****Basic Pump
Model T10A3S-B
Size 10" x 10"**

PUMP SPECIFICATIONS

Size: 10" x 10" (254 mm x 254 mm) Flanged.
Pump Casing: Gray Iron No. 30. Maximum Operating Pressure 99 psi (683 kPa).
Open Type, Two Vane Impeller: Ductile Iron No. 65-45-12. Handles 3" (76.2 mm) Diameter Spherical Solids.
Impeller Shaft: Stainless Steel No. 17-4 PH.
Replaceable Front Wear Plate: Ductile Iron No. 65-45-12.
Replaceable Rear Wear Plate: Carbon Steel Plate.
Removable Clean-out Cover Plate: Gray Iron No. 30; 9 lbs. (4 kg).
Flap Valve: Neoprene w/Steel Reinforcing.
Bearing Housing: Gray Iron No. 30.
Seal Plate: Gray Iron No. 30.
Shaft Sleeve: Alloy Steel No. 4130.
Radial/Thrust Bearings: Open Double Ball.
Bearing and Seal Cavity Lubrication: SAE No. 30 Non-Detergent Oil.
Suction Flange: 125# Gray Iron No. 30.
Suction Head: Gray Iron No. 30.
Gaskets: Buna-N, PTFE, Cork, and Rubber.
O-Rings: Buna-N.
Hardware: Standard Plated Steel.
Brass Pressure Relief Valve.
Bearing and Seal Cavity Oil Level Sight Gauges.
Optional Equipment: Metal Bellows Seal. Automatic Air Release Valve. High Pump Temperature Shutdown Kit. 120V/240V Casing Heater. Gray Iron No. 30 Spool Flanges; 10" ASA Discharge.
 250 mm DIN 2527 Suction and Discharge
(Specify Model T10A3S-B /FM).

**Optional Flanges Available in ASA or DIN Standard Sizes.**

SEAL SPECIFICATIONS

Cartridge Type, Mechanical, Oil-Lubricated, Double Floating, Self-Aligning. Tungsten Titanium Carbide Rotating and Stationary Faces. Stainless Steel No. 316 Stationary Seat. Stainless Steel No. 18-8 Cage and Spring. Maximum Temperature of Liquid Pumped, 160°F (71°C).*

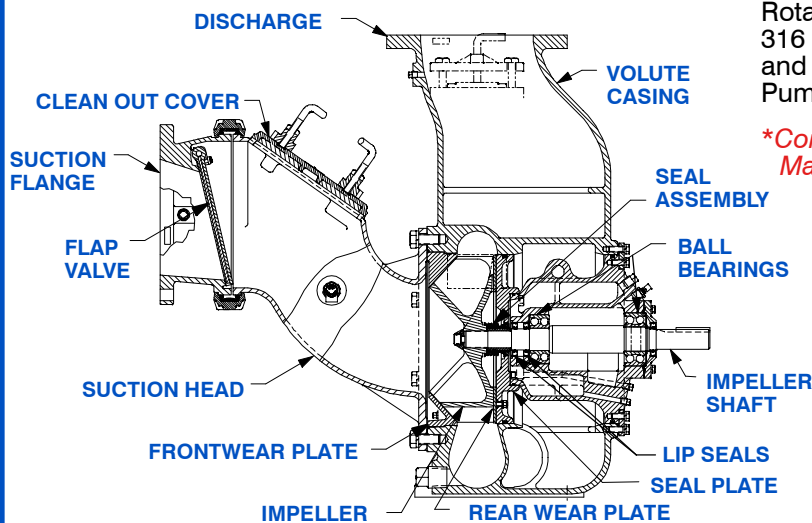
**Consult Factory for Applications Exceeding Maximum Pressure and/or Temperature Indicated.*

SEAL DETAIL

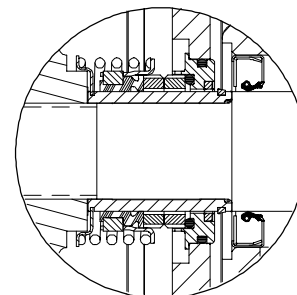
**THE GORMAN-RUPP COMPANY • MANSFIELD, OHIO**

GORMAN-RUPP OF CANADA LIMITED • ST. THOMAS, ONTARIO, CANADA

www.gormanrupp.com

Specifications Subject to Change Without Notice

Printed in U.S.A.

Specification Data

NET WEIGHT: 1401 LBS. (635 KG.)*
SHIPPING WEIGHT: 1461 LBS. (663 KG.)*
EXPORT CRATE: 53.0 CU. FT. (1,5 CU. M.)
***ADD 71 LBS. (32,2 KG.) W/DISCH SPOOL FLANGE**

SECTION 55, PAGE 2400

APPROXIMATE DIMENSIONS and WEIGHTS

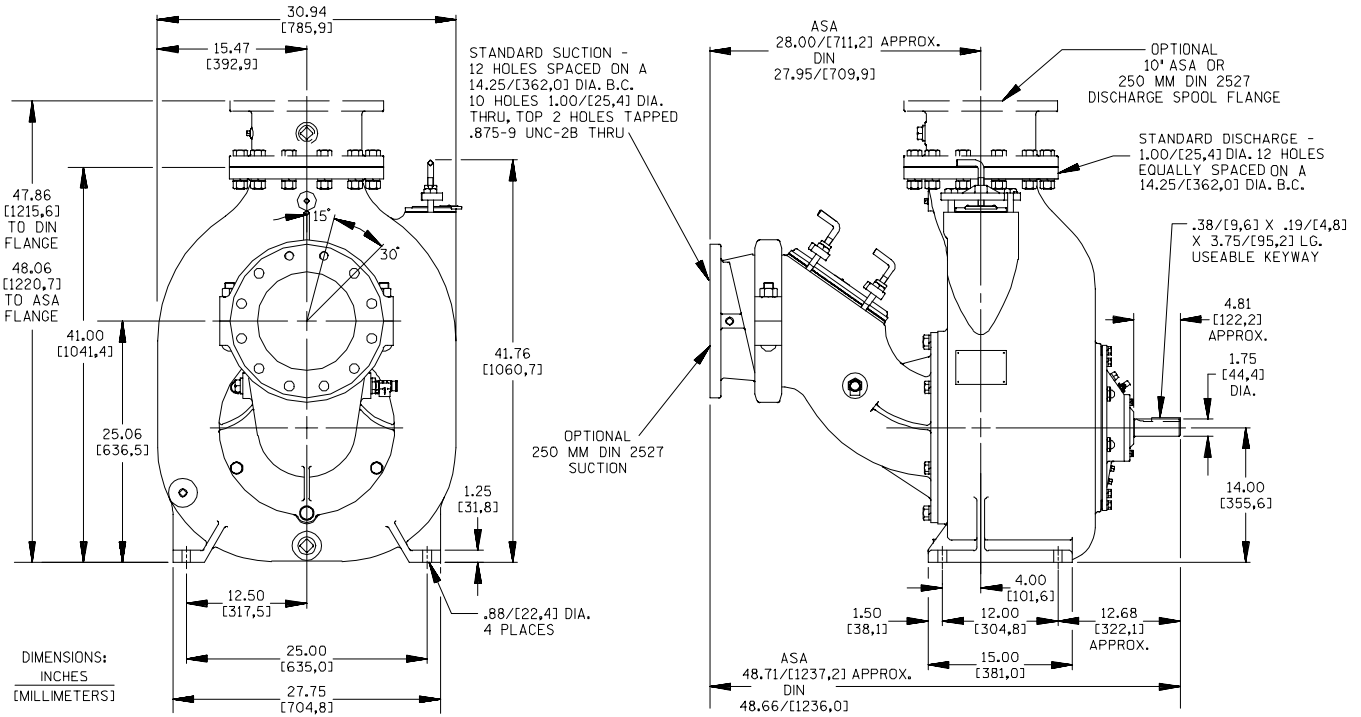

OPTIONAL ASA OR DIN STANDARD SPOOL FLANGES AVAILABLE

REPRIMING LIFTS

RPM	650	750	850	950	1050-1150	1250	1350-1450
FEET	7	11	14	17	18	19	22
METERS	2.1	3.4	4.3	5.2	5.5	5.8	6.7

Figure NPSH required prior to using above table. DO NOT use as available Suction Lifts. 3.00"/[76,2 MM] DIA. MAX. SPHERICAL SOLIDS

38222-701 T10A-B-4
 38615-014 T10A-B
 S 10"X10" 14.75"

Note: Select performance within operating range of curve.

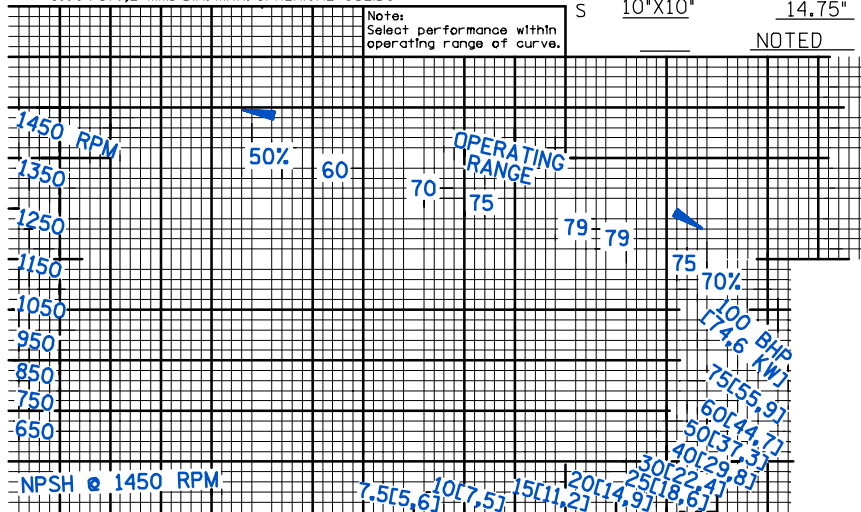

T-5-99-R