

A B C D E

## Basic Pedestal

## Self Priming Centrifugal Pump

Models 86B3-B and 86B52-B

Size 6" x 6"



## PUMP SPECIFICATIONS

**Size:** 6" x 6" (152 mm x 152 mm) NPT - Female.  
**Casing:** Gray Iron No. 30.  
 Maximum Operating Pressure 78 psi (538 kPa)\*.  
**Semi-Open Type, Four Vane Impeller:** Gray Iron No. 30.  
 Handles 1 3/4" (44,5 mm) Diameter Spherical Solids.  
**Impeller Shaft:** Alloy Steel No. 4150.  
**Replaceable Wear Plate:** Gray Iron No. 30.  
**Pedestal:** Gray Iron No. 30.  
**Seal Plate:** Gray Iron No. 30.  
**Shaft Sleeve:** Alloy Steel No. 4130.  
**Flap Valve:** Buna-N and Steel.  
**Radial Bearings:** Open Single Row Ball.  
**Thrust Bearings:** Open Double Row Ball.  
**Bearing Lubrication:** SAE No. 30 Non-Detergent Oil.  
**Flanges:** Gray Iron No. 30.  
**Gaskets:** Cork.  
**O-Rings:** Buna-N  
**Hardware:** Standard Plated Steel and Stainless Steel.  
**Oil Level Sight Gauge.**  
**Optional Equipment:** Consult Factory.



*\*Consult Factory for Applications Exceeding Maximum Pressure and/or Temperature Indicated.*

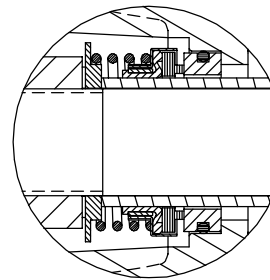
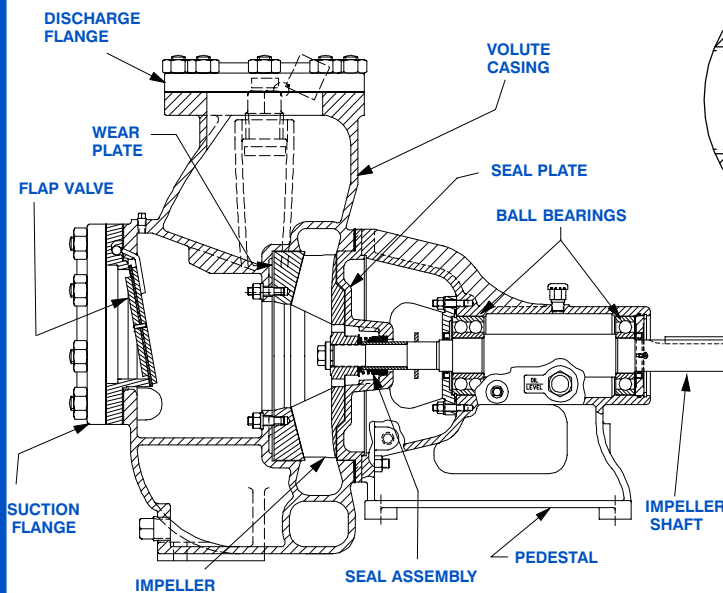

**86B3-B SEAL DETAIL** Type 21, Mechanical, Self-Lubricated. Carbon Rotating Face. Ni-Resist Stationary Face. Fluorocarbon Elastomers (DuPont Viton® or Equivalent). Stainless Steel No. 18-8 Cage and Spring. Maximum Temperature of Liquid Pumped, 160°F (71 °C).\*

**86B52-B SEAL DETAIL** Type 31, Mechanical, Self-Lubricated. Silicon Carbide Rotating and Stationary Faces. Fluorocarbon Elastomers (DuPont Viton® or Equivalent). Stainless Steel No. 18-8 Cage and Spring. Maximum Temperature of Liquid Pumped 160°F (71 °C).\*

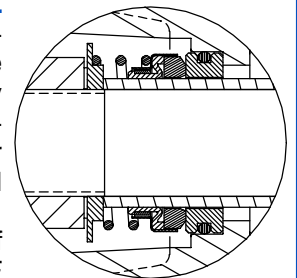

86B52-B SHOWN



THE GORMAN-RUPP COMPANY • MANSFIELD, OHIO

GORMAN-RUPP OF CANADA LIMITED • ST. THOMAS, ONTARIO, CANADA

www.grpumps.com

Specifications Subject to Change Without Notice

Printed in U.S.A.

**Specification Data**

SECTION 50, PAGE 2051

APPROXIMATE  
DIMENSIONS and WEIGHTS

NET WEIGHT: 630 LBS. (285,8 KGS.)

SHIPPING WEIGHT: 680 LBS. (308,4 KGS.)

EXPORT CRATE: 24.5 CU. FT. (0,69 CU. M.)

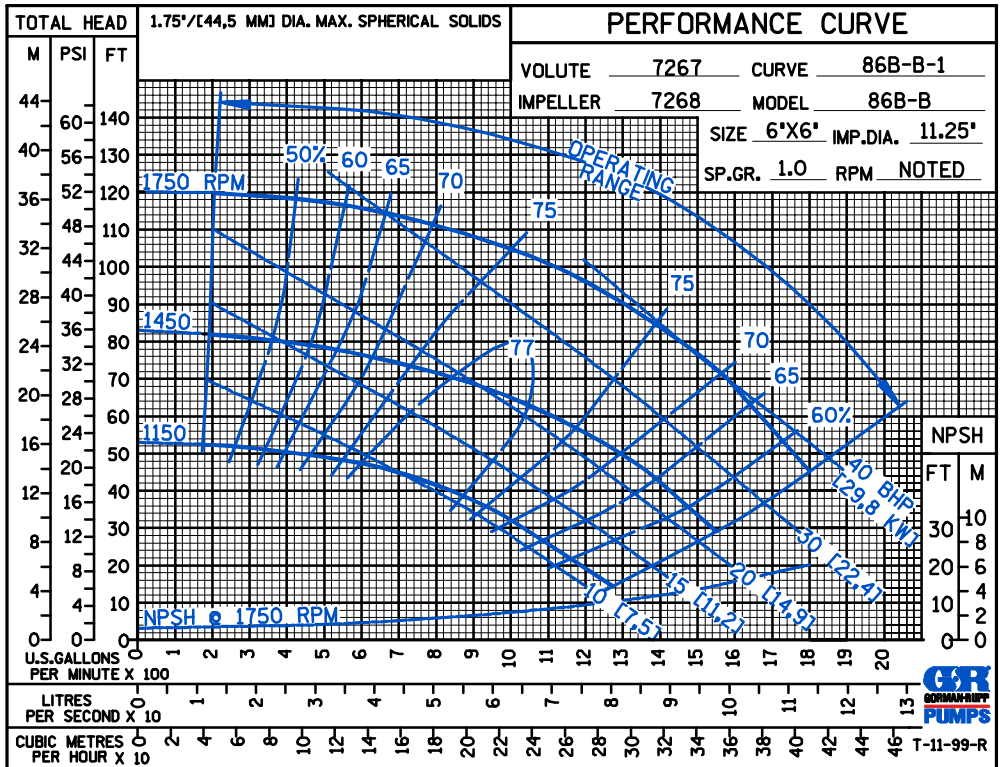
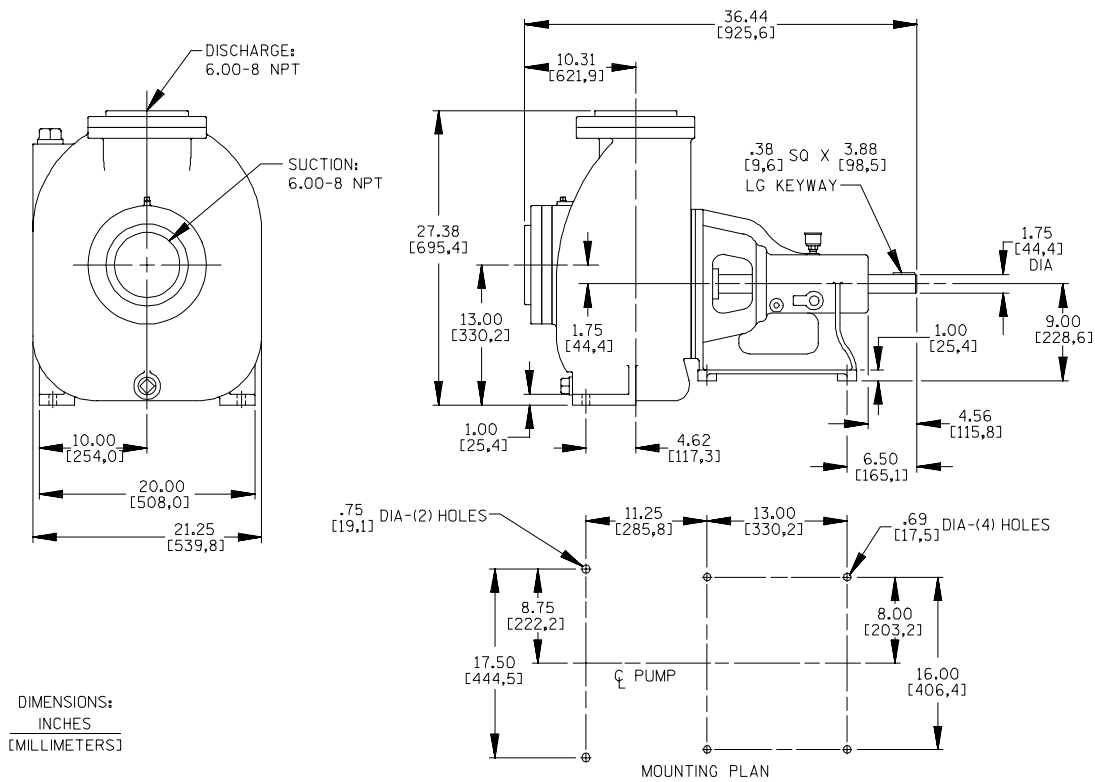

THE GORMAN-RUPP COMPANY • MANSFIELD, OHIO

GORMAN-RUPP OF CANADA LIMITED • ST. THOMAS, ONTARIO, CANADA

Specifications Subject to Change Without Notice

Printed in U.S.A.