



TECHNICAL CHARACTERISTICS

- Aluminium alloy construction
- Smooth operation
- High efficiency impeller
- Maintenance free
- Mountable in any position
- G1/8" female thread on both suction and discharge silencer port flanges.

OPTIONS

- Special voltages (IEC 38)
- Surface treatments

Possible alternative positions, please refer to drw SI 1822

Dimensions in mm.
Dimensions for reference only

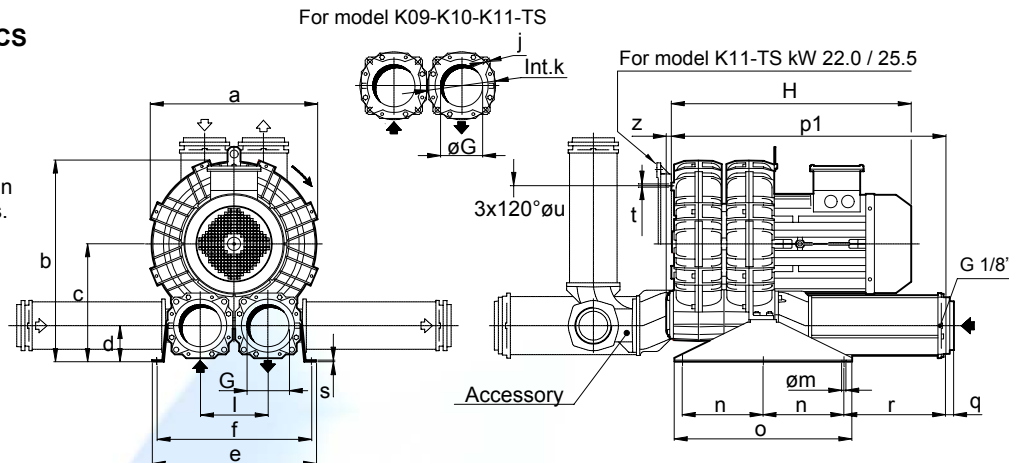

Model	a	b	c	d	e	f	G	l	j	k	m	n	o	p1	q	r	s	t	u	z
K07-TS	424	531	319	98	468	438	G 4"	182	-	-	13	250	550	802	25	299	5	M8	295	16
K08-TS	457	548	319	98	478	448	G 4"	182	-	-	13	250	550	802	25	299	5	M8	310	16
K09-TS	492	610	365	112	508	478	130	210	M16	210	13	250	550	850	-	315	5	M8	360	16
K10-TS	516	623	365	112	508	478	130	210	M16	210	13	250	550	850	-	315	5	M8	360	16
K11-TS	542	650	380	106	540	510	130	228	M16	210	13	250	550	870	-	320	5	M8	390	16

Model	Maximum flow m³/h		Installed power kW		Maximum differential pressure Δp hPa (mbar)		Noise Level Lp dB (A) (1)		Overall dimensions H mm	Weight Kg
	50 Hz 2900 rpm	60 Hz 3500 rpm	50 Hz 2900 rpm	60 Hz 3500 rpm	50 Hz 2900 rpm	60 Hz 3500 rpm	50 Hz 2900 rpm	60 Hz 3500 rpm		
K07-TS	827	998	5.5	6.3	150	110	82.5	84.5	585	88.0
			7.5	8.7	225	200	82.8	84.8	620	93.0
			9.2	10.6	275	250	83.1	85.1	620	102.5
			11.0	12.7	300	300	83.4	85.4	620	103.5
			-	17.4	-	350	-	85.7	620	109.5
K08-TS	1007	1215	5.5	6.3	100	60	78.9	80.9	585	91.5
			7.5	8.7	160	120	79.2	81.2	620	96.5
			9.2	10.6	210	170	80.7	82.7	620	106.0
			11.0	12.7	260	220	80.9	82.9	620	107.0
			15.0	17.4	325	325	81.1	83.1	620	113.0
K09-TS	1325	1600	9.2	10.6	145	110	80.1	82.1	650	116.0
			11.0	12.7	190	150	82.2	84.2	650	117.0
			15.0	17.4	270	240	84.1	86.1	650	128.0
			18.5	21.5	325	275	86.1	88.1	745	158.0
K10-TS	1539	1858	11.0	12.7	160	125	87.1	89.1	650	122.0
			15.0	17.4	225	180	87.4	89.4	650	133.0
			18.5	21.5	275	260	87.7	89.7	745	163.0
K11-TS	1765	2130	11.0	-	100	-	87.3	-	665	135.0
			15.0	17.4	160	105	88.0	90.0	665	146.0
			18.5	21.5	220	165	88.7	90.7	760	176.0
			22.0 ⁽²⁾	25.5 ⁽²⁾	275	220	89.3	91.3	800	186.5

(1) Noise measured at 1 m distance with inlet and outlet ports piped, in accordance to ISO 3744.

(2) K11-TS kW 22.0 50 Hz / 25.5 60 Hz vertical assembly only.

- For proper use, the blower should be equipped with inlet filter and safety valve; other accessories available on request.
- Ambient temperature from -15° to +40°C.
- Specifications subject to change without notice.



LATERAL CHANNEL BLOWERS - EXHAUSTERS SCL K07 / K08 / K09 / K10 / K11

TS SERIES - MOR RANGE

SN 1823-9 2/2

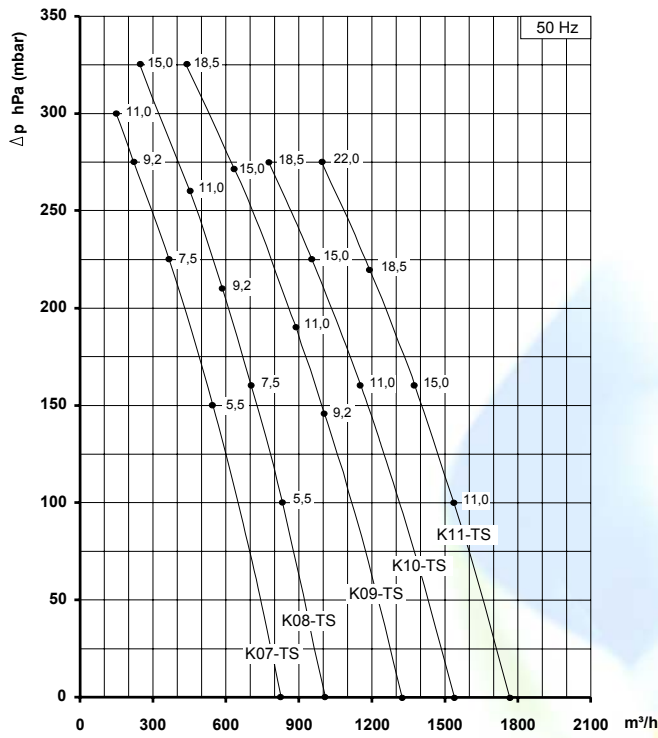

CAPACITY

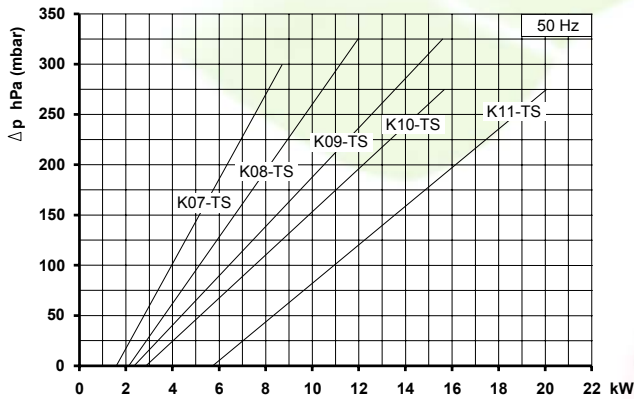
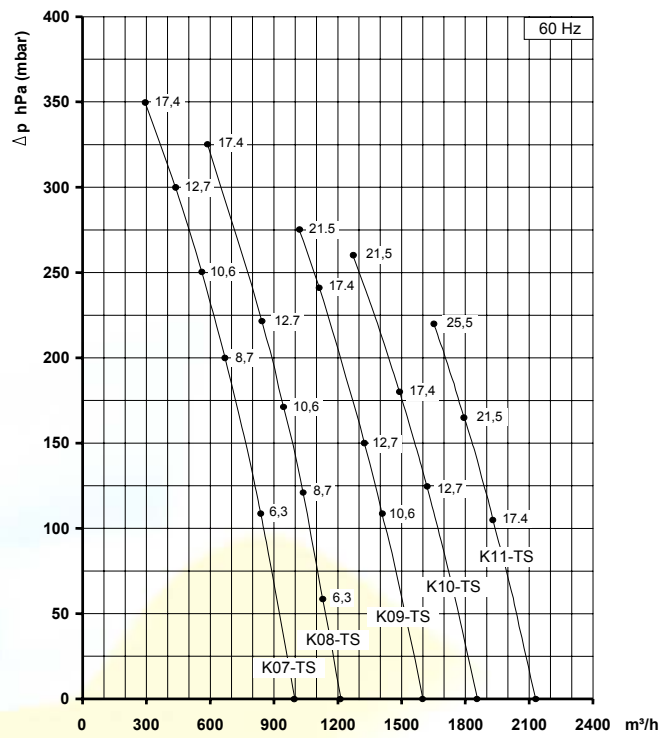

ABSORBED POWER

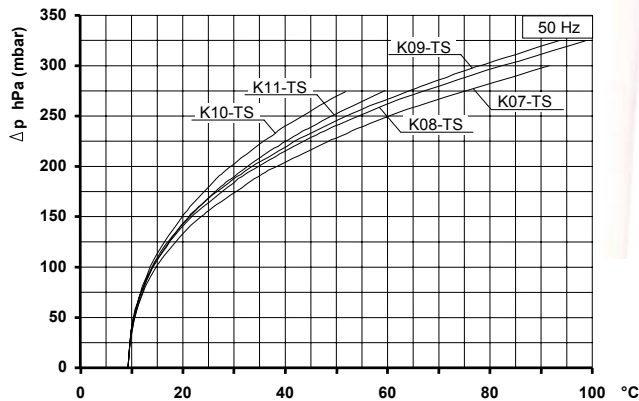
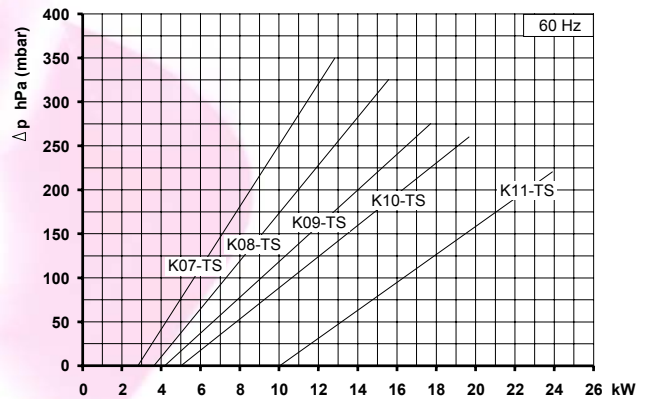

TEMPERATURE INCREASE

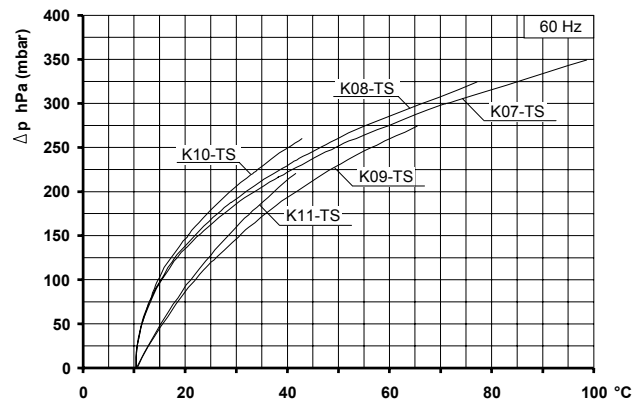

Curves refer to air at 20°C temperature, measured at inlet port and 1013 mbar (abs) atmospheric backpressure.
Values for flow, power consumption and temperature rise: +/-10% tolerance.
Data can change without prior notice.