

AIR FLOW RATE - WATER DEPTH CURVES

The air flow rates are expressed at the standard condition (temperature 20°C, 1 atm) and may vary by up to approximately 5%.

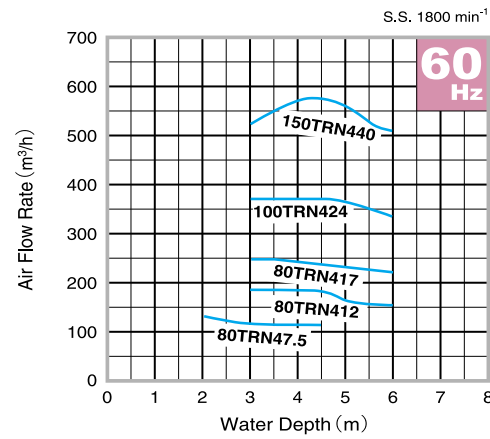

DIMENSIONS

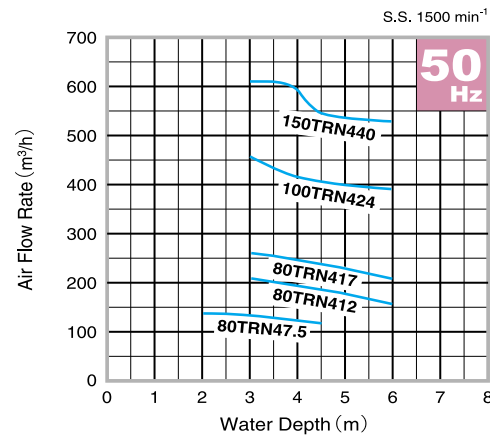
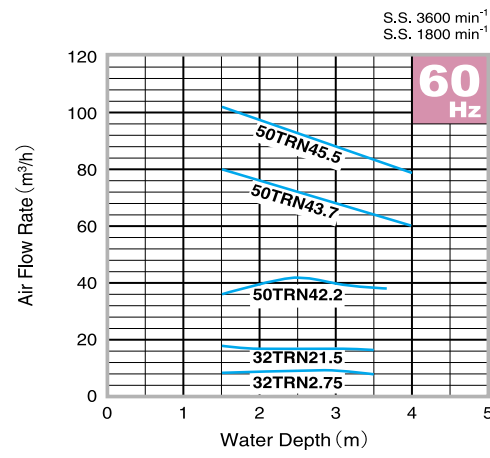
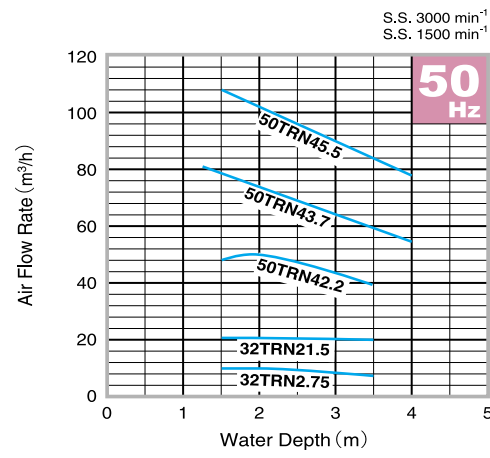
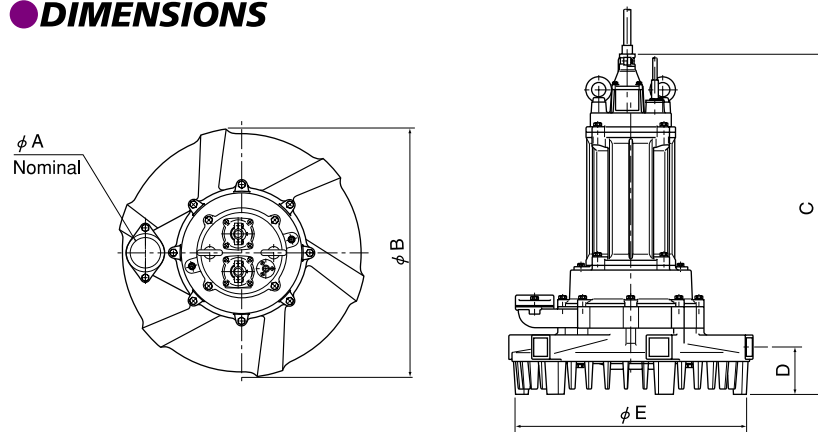

MODEL	A	B	C	D	E
32TRN2.75	32	400	473	81	371
32TRN21.5	32	400	473	81	371
50TRN42.2	50	700	689	123	660
50TRN43.7	50	700	694	123	660
50TRN45.5	50	700	835	123	660
80TRN47.5	80	700	868	133	660
80TRN412	80	700	898	133	660
80TRN417	80	700	958	133	660
100TRN424	100	1000	1254	272	980
150TRN440	150	1000	1407	269	980

Silencer & Valve Set

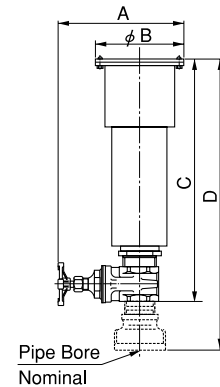

Pipe Bore	A	B	C	D
φ 32	180	116	275	—
φ 50	230	154	370	—
φ 80	245	180	—	585
φ 100	345	256	—	760
φ 150	448	370	740	930

The specifications and designs herein may be changed for improvement without notice.

TSURUMI
MANUFACTURING CO.,LTD.

Your Dealer



Submersible Aerator TRN

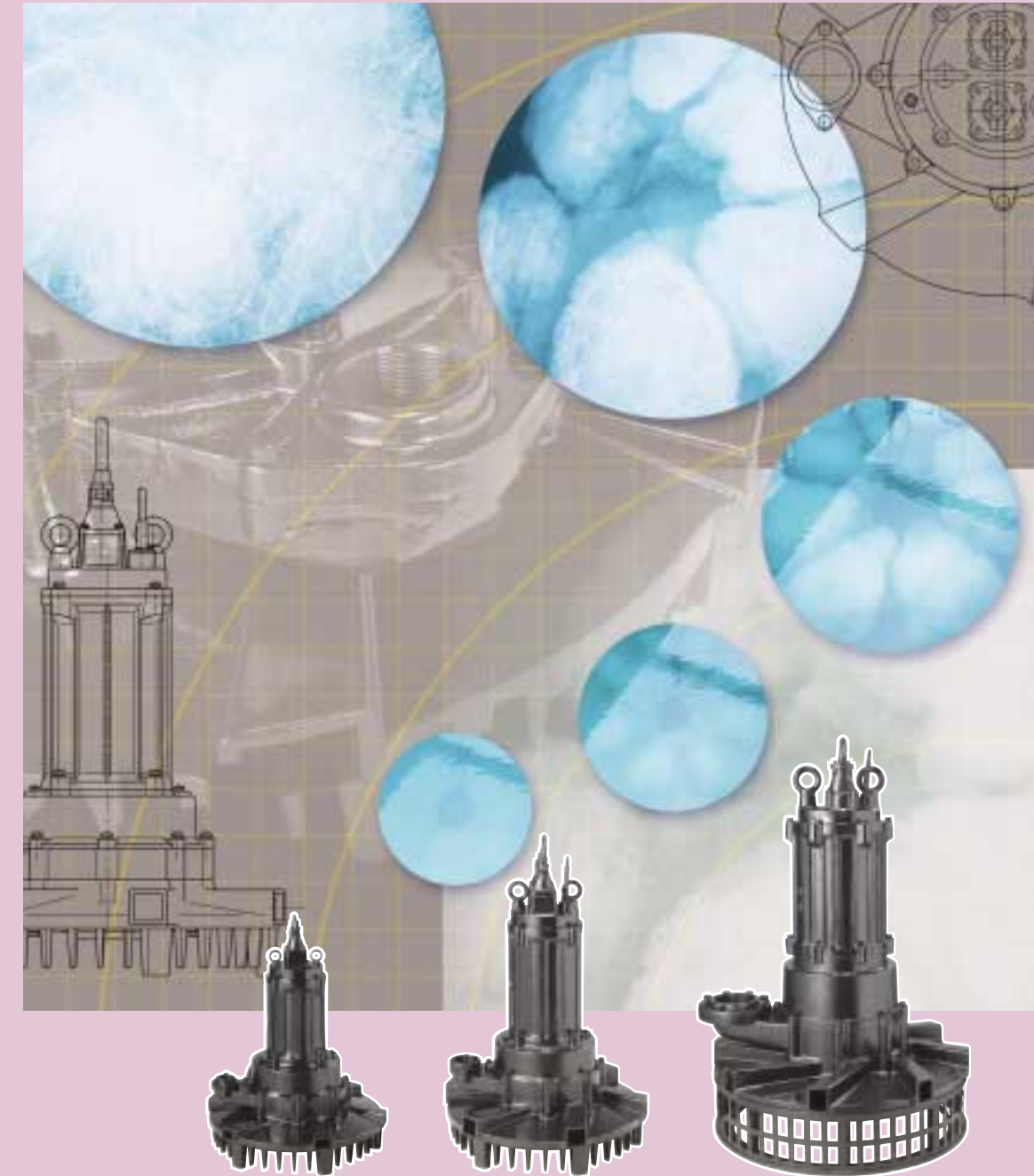

MODEL TRN

SUBMERSIBLE AERATOR

Features of the TRN Series Submersible Aerator

Self-Aspirating Design

The specially designed impeller generates negative pressure around itself when rotating. This negative pressure draws in air from above the water surface. As a result, this equipment aerates without the need for a blower. (A blower is required for deep-water aeration.)

In addition, no diffuser piping is required; the aerator requires air intake piping only.

High Efficiency Dissolution of Oxygen

The air drawn into the aerator is pressurized by the liquid impelled by the impeller. Both the liquid and the pressurized air are pushed toward the discharge port by the guide vane. As part of this process, the air and liquid are mixed at a pressure higher than that produced by the depth of the water. This innovation contributes to highly efficient dissolution of oxygen.

Air Seal Mechanism

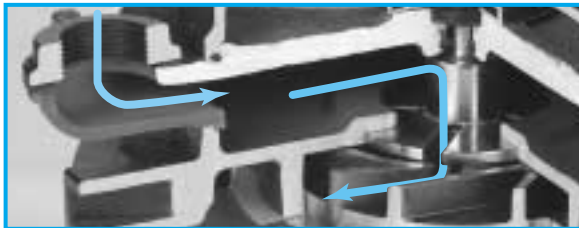

The air seal mechanism prevents pressure on the shaft seal during its operation.

Dual-inside Mechanical Seal & OIL LIFTER

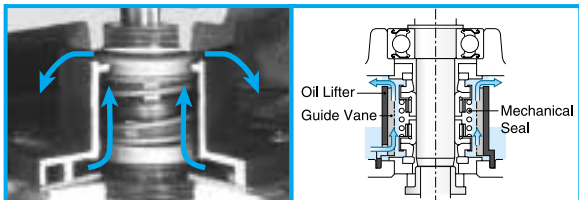

Being located in a clean environment, the mechanical seal assures reliable sealing. The OIL LIFTER stabilizes and enhances mechanical seal lubrication and cooling effect.

Semi-open Impeller (special)



Excellent Stirring Performance

The air contained in the air/liquid mixture discharged from the aerator gives buoyancy to the mixture, and the upward flow of the buoyant liquid generates convection current in the tank. The current stirs the liquid so that it may even out the oxygen translation throughout the tank.

Outstanding Durability

This aerator incorporates a dual-inside mechanical seal, Tsurumi's field-proven shaft seal mechanism. An Oil Lifter is also provided to extend the service life of the mechanical seal. In addition, this aerator includes Tsurumi's proprietary air seal mechanism, which significantly extends the service life of the shaft seal mechanism.

Additional Features

This aerator features the same unique technologies adopted in Tsurumi's submersible pumps. These include the wick-proof cable block, which protects the motor from water intrusion through the cable conductors; motor protection, which protects motor from overload; and an oil seal that protects the mechanical seal from abrasive particles.

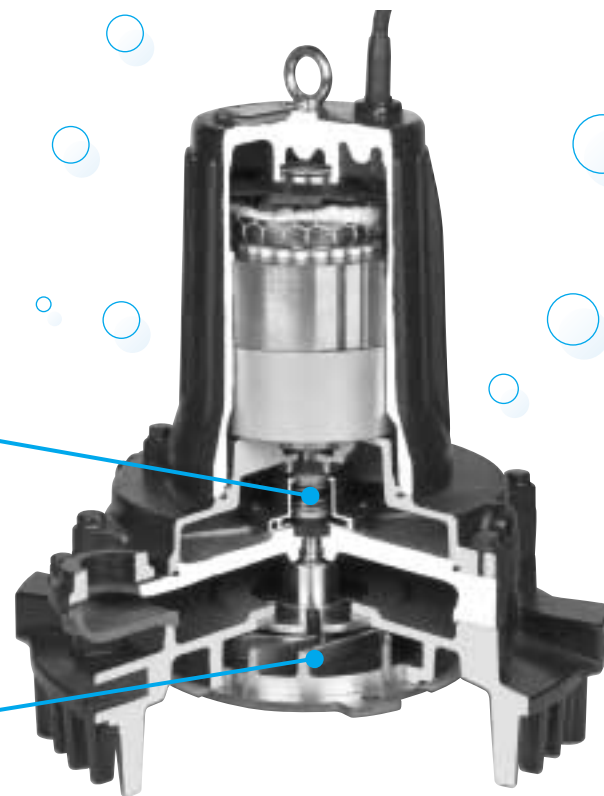

CONVECTION PATTERN

Main Convection

Convection made by rising bubbles. (The minimum distance that must be provided between each aerator)

Sub-convection

The maximum convection that can keep solids suspended to prevent sedimentation of solids.

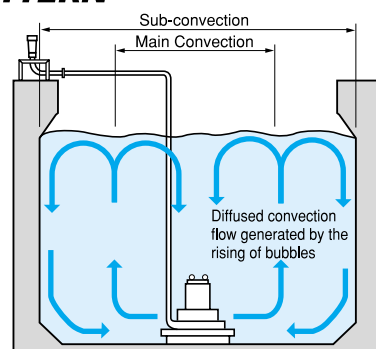

Model	Max. Water Depth m	Main Convection φ m	Sub-convection	
			Circular Tank φ m	Square Tank m
32TRN2.75	3.5	1.4	3.5	3
32TRN21.5	3.5	1.8	4.5	4
50TRN42.2	3.6	2.4	6	5.5
50TRN43.7	4	3	7	6.5
50TRN45.5	4	3.8	9	8
80TRN47.5	4.5	4.4	10	9
80TRN412	6	5.2	12	11
80TRN417	6	5.6	13	11.5
100TRN424	6	6.3	14.5	13
150TRN440	6	7.3	17	15

MAJOR STANDARD SPECIFICATIONS

Air-inlet Bore		mm	32	50	80	100	150
Treating Fluid	Type of Fluid	Wastewater and Sewage					
	Wastewater and Sewage	0 to 40°C					
Aerator	Structure	Impeller	Semi-open Impeller (special)				
		Shaft Seal	Dual-inside Mechanical Seal with Oil Lifter				
		Bearing	Double-shielded Ball Bearing				
	Materials	Impeller	410 Stainless Steel Casting				
		Air Passage	Gray Iron Casting				
		Guide Vane	Gray Iron Casting				
Suction Cover	410 Stainless Steel Casting						
	Shaft Seal	SiC					
Motor	Type, Pole	Dry Type Submersible Induction Motor					
		2, 4-pole (2.2kW and above)					
	Class of Insulation	Class F					
	Phase	Three-phase					
	Starting Method	Direct on Line (7.5kW and below)					
		Star-delta (12kW and above)					
	Protection Device (built-in)	Circle Thermal Protector (7.5kW and below)					
Miniature Thermal Protector (12kW and above)							
Lubricant	Turbine Oil (ISO VG32)						
Materials	Frame	Gray Iron Casting					
	Shaft	420 Stainless Steel					
	Cable	PVC (3.7kW and below)					
		Chloroprene Rubber (5.5kW and above)					
No. of Outlet		6 (17kW and below)					
		8 (24kW and 40kW only)					

APPLICATIONS

- Pre-aeration and aeration at industrial wastewater treatment facilities.
- Oxygen supply to water at aquafarms.

STANDARD ACCESSORIES

- Silencer & Valve Set ----- 1 set
- Screwed Flange (with Packing & Bolts / 17kW and below) ----- 1 set
- JIS 10K Flange (with Packing & Bolts / 24kW and above) ----- 1 set

CABTYRE CABLES

Motor Output kW	200~240V		380~525V		Material	Length m
	Cores×mm ²	Dia. mm	Cores×mm ²	Dia. mm		
0.75	4×1.25	11.1	4×1.25	11.1	PVC	6
1.5	4×1.25	11.1	4×1.25	11.1	PVC	6
2.2	4×2	11.8	4×2	11.8	PVC	6
3.7	4×3.5	13.9	4×2	11.8	PVC	6
5.5	4×3.5	14.1	4×3.5	14.1	Chloroprene Rubber	8
7.5	4×5.5	16.8	4×5.5	16.8	Chloroprene Rubber	8
12	4×3.5	14.1	4×3.5	14.1	Chloroprene Rubber	8
	3×3.5	12.9	3×3.5	12.9		
17	4×5.5	16.8	4×5.5	16.8	Chloroprene Rubber	8
	3×5.5	15.2	3×5.5	15.2		
24	4×14	21.7	4×14	21.7	Chloroprene Rubber	10
	3×14	19.7	3×14	19.7		
40	4×22	28.8	4×14	21.7	Chloroprene Rubber	10
	3×25	26.1	3×14	19.7		
	2×1.25	10.5	2×1.25	10.5		

STANDARD SPECIFICATIONS

Air-inlet Bore mm	Model	Motor Output kW	Speed (S.S.) 50/60Hz min ⁻¹	Starting Method	Max. Water Depth m	Air Flow Rate - Max. Water Depth* 50/60Hz m ³ /h	No. of Outlets	Impeller Passage mm	Dry Weights** kg
32	32TRN2.75	0.75	3000/3600	D.O.L	3.5	7/8	6	10	55
	32TRN21.5	1.5	3000/3600	D.O.L	3.5	20/17	6	12	55
50	50TRN42.2	2.2	1500/1800	D.O.L	3.6	39/38	6	12	140
	50TRN43.7	3.7	1500/1800	D.O.L	4.0	55/60	6	12	150
	50TRN45.5	5.5	1500/1800	D.O.L	4.0	78/79	6	15	170
80	80TRN47.5	7.5	1500/1800	D.O.L	4.5	124/112	6	15	190
	80TRN412	12	1500/1800	Star-delta	6.0	157/155	6	15	200
	80TRN417	17	1500/1800	Star-delta	6.0	202/220	6	15	220
100	100TRN424	24	1500/1800	Star-delta	6.0	388/342	8	22	460
150	150TRN440	40	1500/1800	Star-delta	6.0	528/506	8	25	635

* The air flow rates are expressed at the standard condition. : Temperature 20°C, 1atm
** Dry Weights excluding cable.